

Residential Accessory Dwelling Units, Accessory Structures & Room Additions

Planning and Development Services Department

www.lawrenceks.org/pds

This covers the basic requirements for accessory dwelling units, accessory structures and room additions for residential one- and two-family dwellings. Consult with the [Planner of the Day](#) at (785) 832-3150 prior to establishing any home occupation business.

This should not be considered as a complete list of City of Lawrence Building Code or Land Development Code requirements. Complete information is available in the [codes](#) and [ordinances adopted by the City](#). The International Code Council (ICC) code books referenced in the City's adopted codes are available for review at the Building Safety Division office at 1 Riverfront Plaza, Suite 110 or the local public library, or can be purchased at the [ICC Book Store](#). Some materials and construction methods may require the use of an architect or other design professional. The City of Lawrence Land Development Code is available online, at the local library or from the Planning Office in City Hall at 455 N. Main St.

PERMITS AND PLANS REQUIRED

- **PERMIT REQUIRED** - A building permit is required for all additions to dwellings, accessory dwelling units and for detached tool and storage sheds exceeding 200 square feet. If the property is in a Planned Zoning District, conditions may apply regarding accessory structures. Contact the [Planner of the Day](#) at (785) 832-3150.
- **APPLICATION FORM** - A fully completed and signed City [building permit application](#) form is required.
- **PLOT PLAN** - A [plot plan](#) drawn to scale showing the lot with lot lines, lot dimensions, streets abutting the lot, proposed new and existing structures on the lot, setbacks of the proposed new accessory structure or building addition from adjacent property lines and other existing structures on the lot, easements and driveways must be provided.
- **CONSTRUCTION DRAWINGS** - Provide floor plan, framing plan, foundation plan, elevations (drawings of the front, rear and sides of a building or building addition) and use of each room, area or space. Drawings prepared and sealed by a Kansas licensed design professional are not generally required unless non-conventional construction is used or new loads are applied to existing structural members; sealed drawings may be required if unusual situations are identified at the time of the building permit plan review. Elevations may not be required for small accessory buildings not located in a design overlay or historic district.
- **ELECTRICAL** - Any electrical wiring to an accessory structure requires an [electrical permit](#) regardless of structure size.
- **LICENSING** – Contractors and sub-contractors (including framing; concrete; electrical; heating, air-conditioning and ventilation; plumbing) are required to be licensed to perform work within the City. An owner may perform as a contractor or sub-contractor provided they are the owner and occupant of the residence and complete and sign the [owner/occupant form](#).

ACCESSORY DWELLING UNITS - DESIGN STANDARDS

An accessory dwelling unit is defined in the Lawrence Land Development Code (LDC) as: "A dwelling unit that is incidental to and located on the same lot as the principal building or use, when the principal building or use is a dwelling." Per the LDC, accessory dwelling units are only allowed in RS40, RS20, RS10, RS&, MU or CN1 zoning districts. The City's [interactive map](#) can be used to determine a property's zoning designation. An accessory dwelling unit is prohibited to have a type B home occupation business per the LDC. Accessory dwelling units shall be registered with the Planning Director prior to their establishment.

PURPOSE

Accessory dwelling unit design standards are intended to ensure that accessory dwelling units: are compatible with the desired character and livability of the zoning districts in which they are located; respect the general building scale and placement of structures to allow sharing of common space on the lot, such as with driveways and yards; and are 960 square feet or smaller in size.

METHODS OF CREATION

- a) Conversion of an existing living area within a detached dwelling, attached dwelling (e.g., attic, basement or attached garage).
- b) Addition of floor area to an existing detached dwelling, attached dwelling or detached garage.
- c) Constructing a new detached dwelling, attached dwelling or detached garage with an internal accessory dwelling unit.

LOCATION OF ENTRANCES

- a) Only one entrance to the principal building may be located on the front facade that faces the street, unless the principal building contained an additional street-facing entrance before the accessory dwelling unit was created.
- b) When the accessory dwelling unit is located behind the rear wall of the principal building, the accessory dwelling entrance shall face the front lot line.
- c) An exception to subsection (b) above is dwelling units that do not have access from the ground such as dwelling units with entrances from balconies or elevated decks.

SIZE

The maximum size of an accessory dwelling unit may be no more than 33% of the living area of the detached dwelling or attached dwelling, or 960 square feet, whichever is less.

SETBACKS

Refer to the Accessory Structures – Design Standards section of this document for setback requirements for accessory structures.

NO CONSTRUCTION ON OR OVER EASEMENTS

Construction of any accessory dwelling unit structure on or over a public or private utility, drainage or access easement is not allowed.

ACCESSORY STRUCTURES - DESIGN STANDARDS

Detached garages, carports, sheds, etc. OTHER THAN Accessory Dwelling Units

BUILDING COVERAGE

- a) A detached accessory structure may not have a larger footprint than the building footprint of the principal building.
- b) The combined footprint of all accessory structures may be equal to the footprint of the principal building or 20% of the lot area, provided the total footprint of all structures does not exceed the maximum building coverage as permitted by Sec. 20-601(a) or (b) of the Lawrence Land Development Code for the corresponding zoning district.
- c) Seasonal crop agriculture structures used to extend the growing season, such as cold frames, low tunnels, and hoop houses that are exempt from building permit requirements are exempt from these building coverage regulations.

BUILDING HEIGHT

- a) Unless otherwise expressly stated, accessory structures may not exceed 25 feet in height, or the height of the principal building on the same lot, whichever is less.

SETBACKS - Measured from the property lines.

- a) Accessory structures in residential districts shall be located to the rear of the front building line and may be located as close as 5' to interior and rear lot lines.
- b) Setbacks from interior side lot lines shall not apply to accessory buildings placed on lots that abut alleys.
- c) An accessory structure may be located up to the rear property line when the lot abuts an alley and when the doors to the building do not open directly onto the alley. There shall be no setback required between an accessory structure and an alley when access to the structure is parallel to the alley, except that no part of the structure shall overhang or otherwise encroach onto the alley.

NO CONSTRUCTION ON OR OVER EASEMENTS

- a) Construction of any accessory structure on or over a public or private utility, drainage or access easement is not allowed.

ROOM ADDITIONS- DESIGN STANDARDS

ROOM ADDITIONS TO MAIN DWELLING - Setbacks for room additions must comply with the setback requirements for the main structure. Main dwelling setbacks below are residential district zoning only.

Standard	RS40	RS20	RS10	RS7	RS5	RS3	RSO	RM12/ RM12D [6]	RM15	RMO	RM24	RM32	RMG
Min. Lot Area (sq. ft.)	40,000	20,000	10,000	7,000	5,000	3,000	5,000	6,000	6,000	5,000	6,000	6,000	10,000
Min. Lot Width (ft.)	150	100	70	60	40	25	50	60	60	50	50	50	50
Min. Lot Frontage	40	40	40	40	40	25	40	60	60	40	50	50	50
Min. Setbacks (ft.):													
Front [5]	25	25	25	25	20	15 [1]	25	25	25	25	25	25	25
Side (Exterior) [2][5]	25/25	25/20	25/15	25/10	20/10	15/10	25/10	25/10	25/10	25/10	25/10	25/10	25/10
Side (Interior) [5]	20	20	10	5	5	5	5	5	5	5	5	5	5
Rear [3][5]	30/35	30/35	30/25	30/25	20/25	20/25	20/25	20/25	25/25	20/25	20/25	20/25	20/25
Max. Bldg. Cover (% of site)	15 [4]	30 [4]	40 [4]	45 [4]	50 [4]	50 [4]	50 [4]	50 [4]	50 [4]	50 [4]	50 [4]	60 [4]	60 [4]

[1] Minimum garage entrance Setback = 20 feet

[2] First number represents minimum Exterior Side Setback when subject Lot is adjacent to an abutting interior Side Lot Line. Second number represents minimum Exterior Side Setback when subject Lot is adjacent to an abutting Rear Lot Line.

[3] First number represents minimum Rear Setback for Single Frontage Lot. Second number represents minimum Rear Setback for double Frontage (or through) Lot.

[4] Applies only to Lots platted after the Effective Date or any improvements on a property after the Effective Date which increase the Building coverage or impervious coverage.

[5] Additional Setback restrictions apply to properties developed adjacent to RS zoned properties where expressly required elsewhere in the Development Code.

[6] Density and Dimensional Standards for the RM12D District are the same as those for the RM12 District.

PERMITTED EXCEPTIONS TO REQUIRED YARD AND SETBACK STANDARDS

- a) Cornices, canopies, eaves or other architectural features may project into required yards up to 2.0 feet.
- b) Unenclosed fire escapes may project into required yards and/or setbacks, provided that they are set back at least 3 feet from all lot lines.
- c) An uncovered stair and necessary landings may project into required yards and/or setbacks, provided they are set back at least 3 feet from all lot lines, and the stair and landing may not extend above the entrance floor of the building except for a railing not exceeding 4 feet in height.
- d) Bay windows, balconies, and chimneys may project into required yards and/or setbacks up to 2 feet, provided that such features do not occupy, in the aggregate, more than 1/3 the length of the building wall on which they are located.
- e) Mechanical structures such as heat pumps, air conditioners, emergency generators, and water pumps are not allowed in required front or side yards, but they may be located in required rear yards if they are located at least 5 feet from the rear lot line.
- f) Vertical structures such as flag poles, trellises and other garden structures, play structures, radio antennas, and lamp posts are allowed in required yards if they are no taller than 30 feet. If they are taller, they are not allowed in required setbacks, except that flag poles are allowed in any required yard.
- g) Uncovered horizontal structures such as decks, stairways, entry bridges and wheelchair ramps that extend no more than 2.5 feet above the ground are allowed in required setbacks; such structures may be enclosed by fences, in accordance with other provisions of this section but shall not be otherwise enclosed.

The entire list of permitted exceptions is available in Chapter 20 Article 6 of the [Land Development Code](#).

DRIVEWAYS AND APPROACHES

- a) Driveway and approach standards are applied when a driveway or approach is moved, rebuilt, or constructed in conjunction with an addition project.

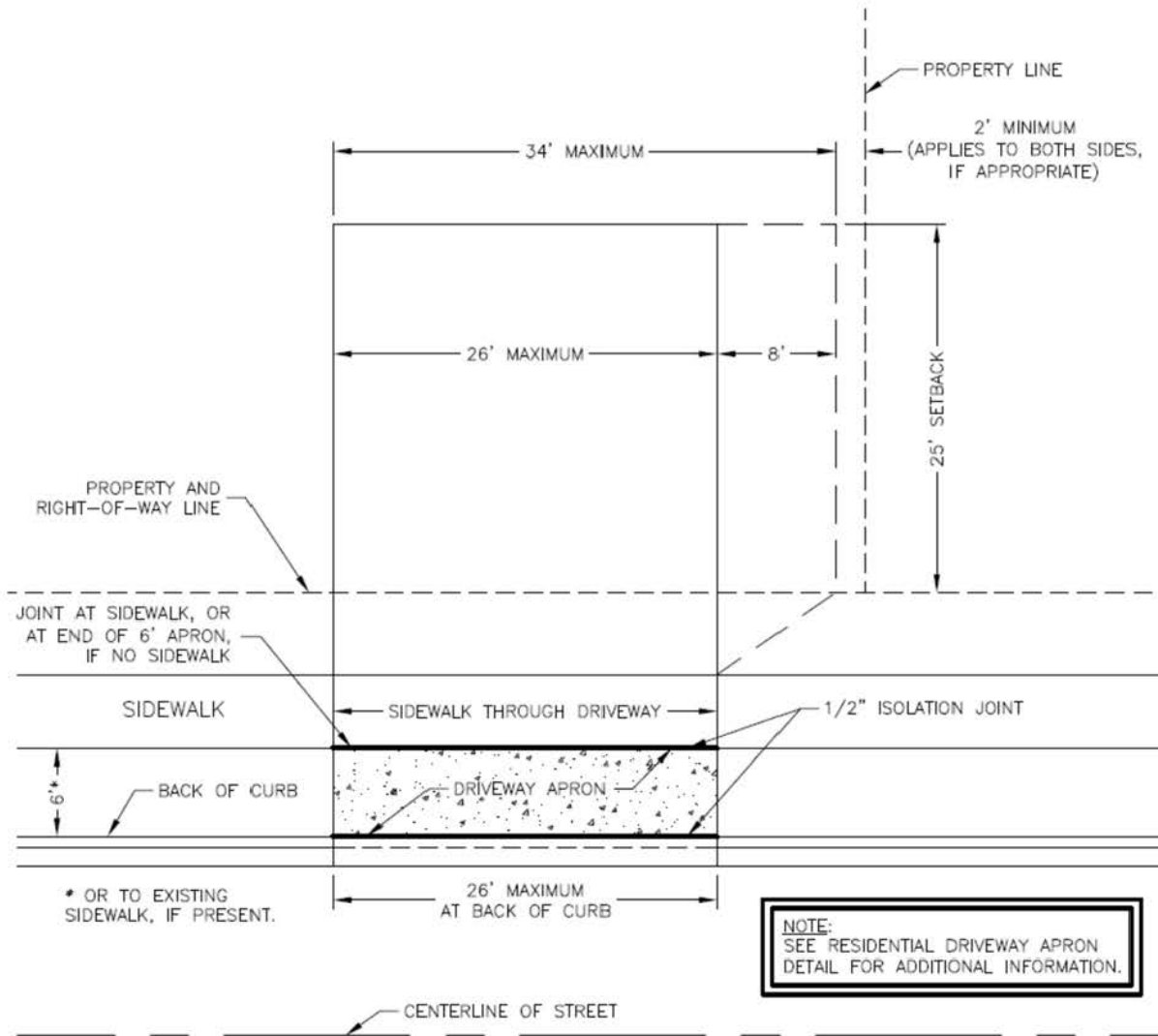

DRIVEWAY DETAIL FOR A SINGLE FAMILY HOME

SCALE : 1"=10'
(SKETCH A)

NOTE: DRIVEWAY APRON MAY BE FLARED, IF DESIRED; HOWEVER, THE MAXIMUM WIDTH AT THE CURB REMAINS AT 26 FEET.

Last Update: 10/21/2008

CONSTRUCTION STANDARDS

APPEARANCE

- a) In design overlay districts exterior appearance shall be compatible with residential construction. Pre-engineered metal buildings are not generally considered compatible with residential construction.

FOUNDATION SYSTEMS

- a) Basement foundations shall comply with the International Residential Code (IRC), Section R401, as adopted by the City of Lawrence.
- b) Foundations shall extend below the frost line to a minimum of 30 inches below grade measured to the bottom of the footing.
- c) Footings for single story structures shall be at least 12 inches wide.
- d) Minimum R10 thermal barrier required for footing, foundation and slab edge.
- e) Structures shall be bolted to the foundation with minimum 1/2-inch diameter anchor bolts embedded at least 7 inches into the concrete (10-inch long bolts) at 6 feet on-center with a bolt within 12 inches of the end of each bottom plate.

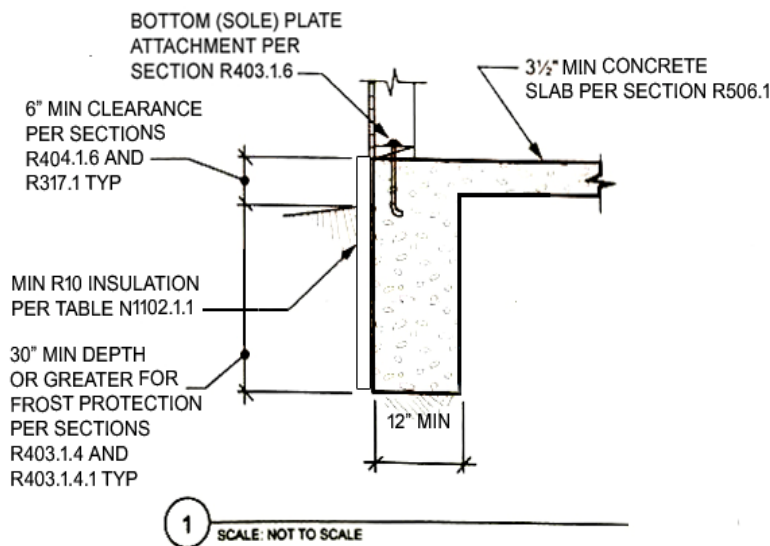

TRENCH FOOTING

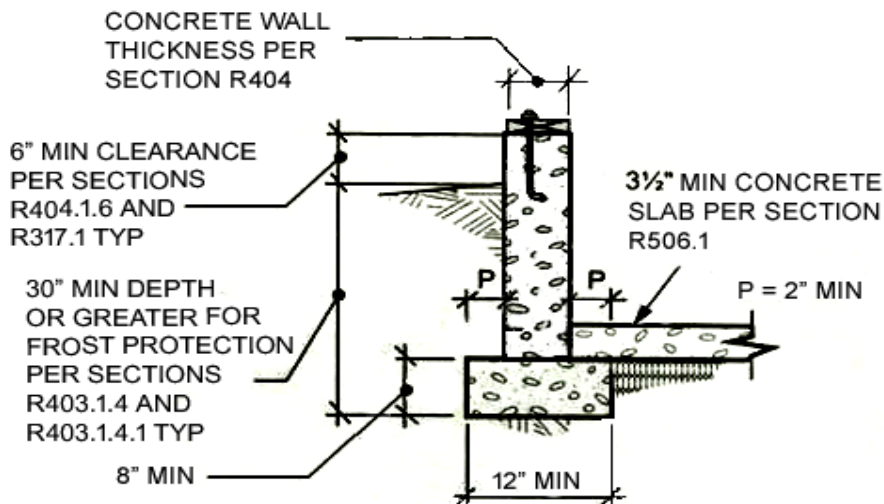

FOUNDATION WALL AND SPREAD FOOTING

FRAMING SYSTEMS

- a) Framing plans shall be drawn to scale and identify all materials used in the construction as to size and grade.
- b) Framing plans for all floor and ceiling joists and rafters shall indicate the spacing between joists and rafters. Spans shall be indicated for all horizontal framing members. See span tables and bracing diagram from adopted International Residential Code (IRC) below.

Floor Joists – 40# LL & 10# DL All Rooms Except Sleeping Areas and Decks				Floor Joists – 30# LL & 10# DL Sleeping Areas			
Member	Species/Grade	Spacing	Max. Span	Member	Species/Grade	Spacing	Max. Span
2x10	DF#2	16" o.c.	15' 7"	2x10	DF#2	16" o.c.	17' 5"
2x10	SPF#2	16" o.c.	15' 5"	2x10	SPF#2	16" o.c.	17' 2"
2x10	HF#2	16" o.c.	15' 2"	2x10	HF#2	16" o.c.	16' 10"
2x10	DF#2	12" o.c.	18' 0"	2x10	DF#2	12" o.c.	19' 10"
Ceiling Joists – 20# LL & 10# DL Limited Attic Storage				Ceiling Joists – 30# LL & 10# DL No Attic Storage			
Member	Species/Grade	Spacing	Max. Span	Member	Species/Grade	Spacing	Max. Span
2x6	HF#2	16" o.c.	12' 8"	2x6	HF#2	16" o.c.	16' 6"
2x6	DF#2	16" o.c.	13' 0"	2x6	DF#2	16" o.c.	17' 8"
2x8	HF#2	16" o.c.	16' 0"	2x8	HF#2	16" o.c.	21' 9"
2x8	DF#2	16" o.c.	16' 6"	2x8	DF#2	16" o.c.	23' 4"
Rafters – 20# LL & 10# DL Ceiling Attached to Rafters				Rafters – 20# LL & 10# DL No Ceiling Attached to Rafters			
Member	Species/Grade	Spacing	Max. Span	Member	Species/Grade	Spacing	Max. Span
2x8	HF#2	16" o.c.	17' 3"	2x6	HF#2	16" o.c.	14' 2"
2x8	HF#2	24" o.c.	14' 8"	2x6	DF#2	16" o.c.	14' 7"
2x8	DF#2	16" o.c.	18' 5"	2x6	DF#2	12" o.c.	16' 10"
2x8	DF#2	24" o.c.	15' 1"	2x8	HF#2	16" o.c.	17' 11"
2x8	SPF#2	16" o.c.	17' 9"	2x8	DF#2	16" o.c.	18' 5"
2x10	HF#2	16" o.c.	21' 11"	2x8	DF#2	12" o.c.	21' 4"
2x10	HF#2	24" o.c.	17' 10"				
2x10	DF#2	24" o.c.	18' 5"				

- c) Headers shall be supported on each end with one or more jack studs or with approved framing anchors. The full-height stud adjacent to each end of the header shall be end nailed to the header with four-16d nails. The minimum number of full-height studs at each end of a header shall be in accordance with IRC Table R602.7.5.

Table R602.7.5

MAXIMUM HEADER SPAN (feet)	ULTIMATE DESIGN WIND SPEED AND EXPOSURE CATEGORY	
	<140mph, Exposure B or ,130 mph, Exposure C	<115mph, Exposure B ^b
≤ 4'	1	1
6' to 8'	2	1
10' to 14'	3	2
16' to 18'	4	2

a. For header spans between those given above, use the minimum number of full-height studs associated with the larger header span.

b. The tabulated minimum number of full-height studs is applicable where jack studs are provided to support the header at each end in accordance with Table R602.7.1(1). Where a framing anchor is used to support the header in lieu of a jack stud in accordance with footnote "d" of Table R602.7(1), the minimum number of full-height studs at each end of a header shall be in accordance with requirements for wind speed < 140 mph, Exposure B.

- d)** All stud wall bottom plates in contact with the concrete shall be CCA/ACQ treated or another wood approved for ground contact.
- e)** Non-bearing walls, except for the perimeter walls, should not be constructed tight between the slab and the floor framing. An expansion joint of approximately 1 inch may be provided to allow for possible movement of the floor slab due to expansion and contraction of the supporting soil over time.
- f)** Hallways shall have a minimum clear width of 3 feet.
- g)** Notching and boring in studs of bearing and non-bearing walls shall not exceed the limitations noted in the diagram below.

If 1-inch expansion joint between the top of non-bearing partitions and the joist above, use angle brace to secure top of wall to the ceiling.

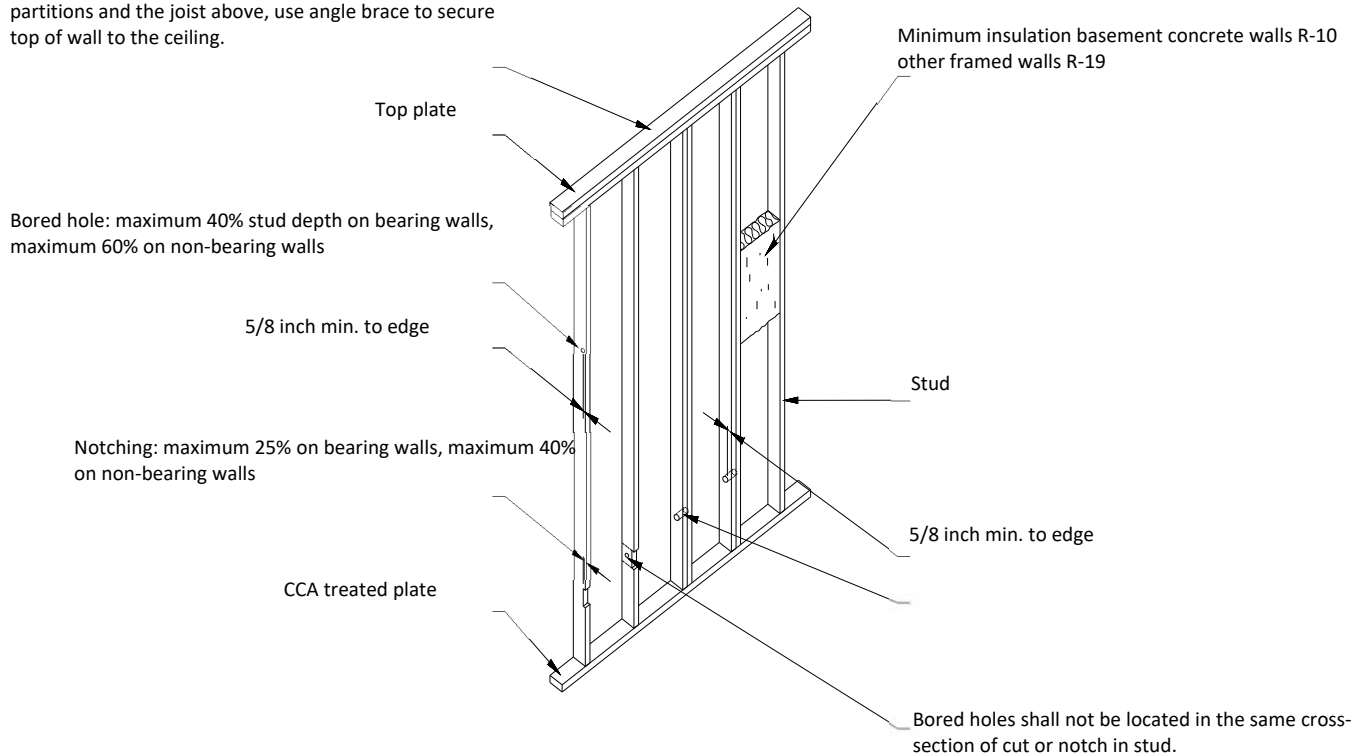

- h)** Walls shall be braced to resist wind and seismic forces. Bracing shall be done in accordance with IRC Section R602.10 Wall Bracing or Section R602.12 Simplified Wall Bracing or by Section R301.1 Engineered Design. Some accepted bracing methods include but are not limited to the following:
 - 1)** Let in nominal 1x4 bracing with an angle from the horizontal of between 45 and 60 degrees with 2-8d nails at each plate and stud (not permitted in first story of multistory structure).
 - 2)** Minimum 48 inches structural panels 5/16-inches thick from the sill plate to the top plate with minimum 6d weather resistant common nails at 12 inches on-center (4x8 and 4x9 panels shall be applied vertically).
 - 3)** Minimum 48-inch hardboard panels 7/16 inches thick installed vertically with edges blocked. Minimum 6d weather resistant common nails at 6 inches on-center (o.c.) at edges and 12 inches on-center at interior supports.
- i)** Where the braced wall length at corners is less than 48 inches in width (such as at next to windows or garage doors) an alternate braced wall panel design or portal frame design can be used as is described in IRC Section R602.10.6.

GLAZING IN HAZARDOUS LOCATIONS

Each pane of glazing installed in hazardous locations shall be provided with a manufacturer's designation specifying who applied the designation, the type of glass and the safety glazing standard with which it complies, which is visible in the final installation. The locations specified below are considered hazardous locations for glazing.

- a) Glazing in fixed and operable panels of swinging, sliding and bifold doors.
- b) Glazing within 24 inches of either side of the door in a closed position and the glazing is less than 60 inches above the floor or walking surface.
- c) The glazing is on a wall perpendicular to the plane of the door in a closed position and within 24 inches of the hinge side of an in-swinging door and the glazing is less than 60 inches above the floor or walking surface.
- d) Glazing in an individual fixed or operable window with the exposed area of an individual pane larger than 9 square feet, has the bottom edge of the glazing less than 18 inches above the floor, with the top edge of the glazing more than 36 inches above the floor and one or more walking surfaces are within 36 inches, measured horizontally and in a straight line, of the glazing.
- e) Glazing in guards and railings, including structural baluster panels and nonstructural in-fill panels.
- f) Glazing that is more than 60 inches, measured horizontally, from the water's edge in walls, enclosures or fences containing or facing hot tubs, spas, whirlpools, saunas, steam rooms, bathtubs, showers and indoor or outdoor swimming pools where the bottom edge of the glazing is less than 60 inches above any standing or walking surface.
- g) Glazing not protected by a guard that is less than 36 inches horizontally and the bottom exposed edge of the glazing is less than 36 inches above the adjacent walking surface of stairways, landings between flights of stairs and ramps.
- h) Glazing not protected by a guard, adjacent to the landing at the bottom of a stairway, and where the glazing is less than 36 inches above the landing and within a 60-inch horizontal arc from the bottom tread nosing.

INSULATION AND FENESTRATION REQUIREMENTS

Lawrence is Climate Zone "4 Except Marine"

Table N1102.1.1 - Insulation and Fenestration Requirements by Component

FENESTRATION U-FACTOR <i>b</i>	SKYLIGHT U-FACTOR <i>b</i>	GLAZED FENESTRATION SHGC <i>b, e</i>	CEILING R-VALUE	WOOD FRAME WALL R-VALUE	MASS WALL R-VALUE <i>i</i>	FLOOR R-VALUE	BASEMENT WALL R-VALUE <i>c</i>	SLAB <i>d</i> R-VALUE & DEPTH	CRAWL SPACE <i>c</i> WALL R-VALUE
0.35	0.55	0.40	49	20 or 13 + 5 <i>h</i>	8/13	19	10 /13	10, 2 ft	10/13

For SI: 1 foot = 304.8 mm.

- b) The fenestration U-factor column excludes skylights. The SHGC column applies to all glazed fenestration.
Exception: Skylights may be excluded from glazed fenestration SHGC requirements in Climate Zones 1 through 3 where the SHGC for such skylights does not exceed 0.30.
- c) "15/19" means R-15 continuous insulation on the interior or exterior of the home or R-19 cavity insulation at the interior of the basement wall. "15/19" shall be permitted to be met with R-13 cavity insulation on the interior of the basement wall plus R-5 continuous insulation on the interior or exterior of the home. "10/13" means R-10 continuous insulation on the interior or exterior of the home or R-13 cavity insulation at the interior of the basement wall.
- d) R-5 shall be added to the required slab edge R-values for heated slabs. Insulation depth shall be the depth of the footing or 2 feet, whichever is less in Zones 1 through 3 for heated slabs.
- e) There are no SHGC requirements in the Marine Zone.
- h) The first value is cavity insulation, the second value is continuous insulation, so "13+5" means R-13 cavity insulation plus R-5 continuous insulation. The second R-value applies when more than half the insulation is on the interior of the mass wall.

EMERGENCY ESCAPE AND RESCUE OPENING

In new single-family dwellings and basement finishes a secondary means of egress from the basement is required for the purpose of emergency escape and rescue. The secondary egress may be a door, or a window meeting the following minimum requirements:

- a) A minimum 5.7 square feet of openable area with a minimum width of 20 inches and a minimum height of 24 inches.
- b) The window well shall measure a minimum 3 feet in width by 3 feet in length.
- c) Interior window sill height measured from finish floor shall not exceed 44 inches.
- d) Window wells with a depth exceeding 44 inches shall be equipped with a permanent ladder.
- e) Ladders or rungs shall have an inside width of at least 12 inches, shall project at least 3 inches from the wall and shall be spaced not more than 18 inches on center vertically for the full height of the window well.

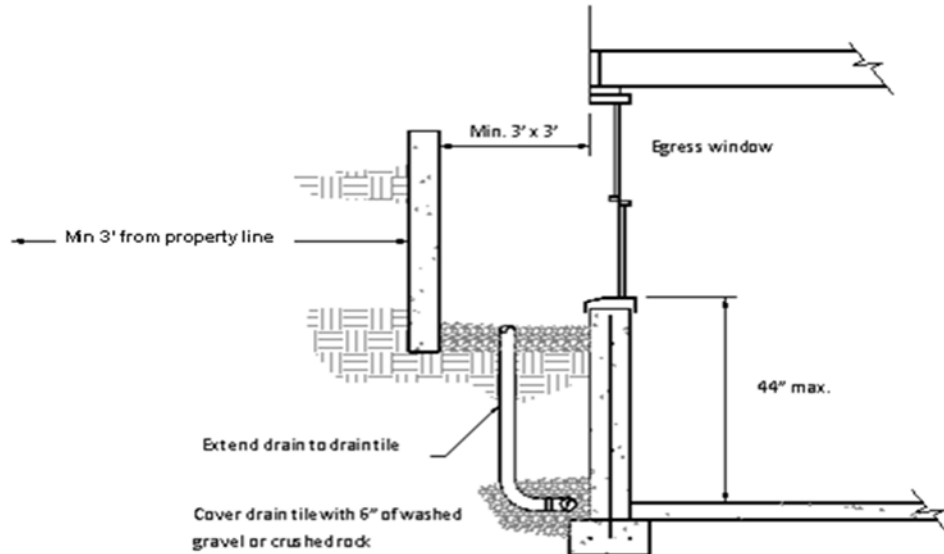

MECHANICAL SYSTEMS

- a) **Size** - Heating and cooling equipment shall be sized based on building loads calculated in accordance with ACCA Manual J or other approved heating and cooling calculation methodologies and shall be submitted with the permit application. Heating and cooling calculations are not required for building additions less than 100 square feet in area.
- b) **Equipment Installation** - Heating and cooling equipment and appliances shall be located with respect to building construction, other equipment and appliances to permit maintenance, servicing and replacement. Clearances shall be maintained to permit cleaning of heating and cooling surfaces; replacement of filters, blowers, motors, controls and vent connections; lubrication of moving parts; and adjustments.
- c) **Ducts** - Joints, longitudinal and transverse seams, and connections in ductwork shall be securely fastened and sealed with welds, gaskets, mastics (adhesives), mastic-plus-embedded-fabric systems, liquid sealants or tapes. Spray polyurethane foam shall be permitted to be applied without additional joint seals.

FUEL GAS AND FUEL GAS APPLIANCES

Examples of fuel gas appliances include furnaces and water heaters that utilize natural gas.

- a) **Unions and Valves** - Access must be maintained to any concealed unions and to any gas valves. Providing an identified access door or removable panel is acceptable.
- b) **Combustion Air Required** - If gas appliances with natural draft design, (most commonly a furnace or water heater with type B vent) are to be enclosed, adequate combustion air (50 cubic feet for each 1,000 Btu/hr.) must be maintained for the appliance to properly operate.

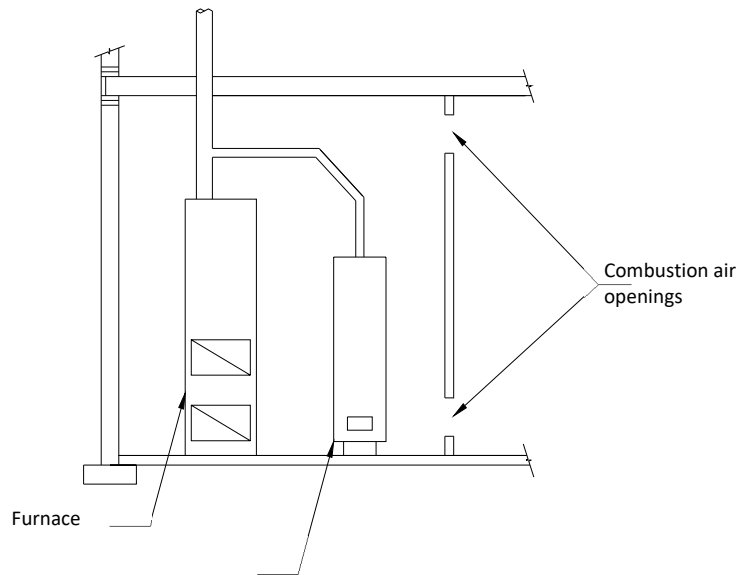

- 1) **Inside combustion air** - Two permanent openings equal to 1 square inch per 1,000 Btu/hr. input rating, but not less than 100 square inches that communicate with adjacent spaces shall be provided. One shall be within 12 inches of the top and one within 12 inches of the bottom of the space. The minimum dimension of air openings shall not be less than three inches.
 - 2) **Outside combustion air** - The most common is one permanent opening, commencing within 12 inches of the top of the enclosure with a minimum free area of 1 square inch per 3,000 Btu/h. The opening shall directly communicate to the outdoors, or spaces that freely communicate with the outdoors. The minimum dimension of air openings shall not be less than three inches.
- c) **Prohibited Locations for Fuel Gas Appliances** – Fuel gas appliances shall not be located in sleeping rooms, bathrooms, toilet rooms, hot tub rooms, storage closets or in a space that opens only into such rooms or spaces, except where the installation complies with one of the following:
- 1. The appliance is a direct-vent appliance installed in accordance with the conditions of the listing and the manufacturer's instructions.
 - 2. Vented room heaters, wall furnaces, vented decorative appliances, vented gas fireplaces, vented gas fireplace heaters and decorative appliances for installation in vented solid fuel-burning fireplaces are installed in rooms that meet the required volume criteria of Section G2407.5.
 - 3. A single wall-mounted unvented room heater is installed in a bathroom and such unvented room heater is equipped as specified in Section 621.6, has an input rating not greater than 6,000 Btu/h (1.76 kW), and a carbon monoxide detector, meeting the requirements of Section R315, is installed in the same room as the appliance. The bathroom shall meet the required volume criteria of Section G2407.5.
 - 4. A single wall-mounted unvented room heater is installed in a bedroom and such unvented room heater is equipped as specified in Section 621.6, has an input rating not greater than 10,000 Btu/h, and a carbon monoxide detector, meeting the requirements of Section R315, is installed in the same room as the appliance. The bedroom shall meet the required volume criteria of Section G2407.5.
 - 5. The appliance is installed in a room or space that opens only into a bedroom or bathroom, and such room or space is used for no other purpose and is provided with a solid weather-stripped door equipped with an approved self-closing device. All combustion air shall be taken directly from the outdoors in accordance with Section G2407.6.

PLUMBING

- a) The water-distribution and drainage system of any building where plumbing fixtures are installed shall be connected to a public water supply or sewer system, respectively.

- b) Material and devices utilized in a plumbing system shall bear the identification of the manufacturer and any markings required by the applicable referenced standards.
- c) A radon pipe extending from the gravel bed under the slab through the structure and terminating out the roof is required on dwelling units.
- d) Every trap and trapped fixture shall be vented with one of the venting methods specified in the code.
- e) Piping shall be:
 - 1) Supported to ensure alignment and prevent sagging, and allow movement associated with the expansion and contraction.
 - 2) Laid on a firm bed for its entire length when in the ground.
 - 3) Supported with hangers and anchors of sufficient strength to carry the weight of pipe and contents and of sufficient width to prevent distortion to the pipe. Hangers and strapping shall be of approved material that will not promote galvanic action.
 - 4) Piping shall be supported at distances not to exceed those indicated in IRC Table P2605.1.

COMMONLY USED MATERIAL FROM TABLE P2605.1

PIPING MATERIAL	MAXIMUM HORIZONTAL SPACING (feet)	MAXIMUM VERTICAL SPACING (feet)
ABS pipe	4	10b
Cast-iron pipe	5a	15
Copper or copper alloy pipe	12	10
Copper or copper alloy tubing (1 1/4 inches in diameter and smaller)	6	10
Copper or copper alloy tubing (1 1/2 inches in diameter and larger)	10	10
PEX (Cross-linked polyethylene pipe), 1 inch and smaller	2.67 (32 inches)	10b
PEX (Cross-linked polyethylene pipe), 1 1/4 inch and larger	4	10b
PEX-AL-PEX (Cross-linked polyethylene/aluminum/cross-linked polyethylene pipe)	2.67 (32 inches)	4b
CPVC pipe or tubing (1 inch in diameter and smaller)	3	10b
CPVC pipe or tubing (1 1/4 inches in diameter and larger)	4	10b
PVC pipe	4	10b
Stainless steel drainage systems	10	10b
Steel pipe	12	15

a. The maximum horizontal spacing of cast-iron pipe hangers shall be increased to 10 feet where 10-foot lengths of pipe are installed.

b. For sizes 2 inches and smaller, a guide shall be installed midway between required vertical supports. Such guides shall prevent pipe movement in a direction perpendicular to the axis of the pipe.

- f) Water heater installation.
 1. Where a storage tank-type water heater or a hot water storage tank is installed in a location where water leakage from the tank will cause damage, the tank shall be installed in a pan constructed of galvanized steel or aluminum not less than 0.0236 inch in thickness or plastic not less than .036 inch in thickness. Plastic pans shall not be installed beneath a gas-fired water heater.

2. The pan shall be not less than 1-1/2 inches deep and shall be of sufficient size and shape to receive dripping or condensate from the tank or water heater. The pan shall be drained by an indirect waste pipe of not less than 3/4 inch diameter. Where a pan drain was not previously installed, a pan drain shall not be required for a replacement water heater installation.
3. Water heaters installed in garages shall be elevated such that the source of ignition is not less than 18 inches above the garage floor. Elevation is not required for appliances that are listed as flammable vapor ignition-resistant.
4. Where heated water is discharged from a solar thermal system to a hot water distribution system, a thermostatic mixing valve shall be installed to temper the water to a temperature of not greater than 140 degrees Fahrenheit. Solar thermal systems supplying hot water for both space heating and domestic uses requires water for space heating at temperatures exceeding 140 degrees Fahrenheit, a master thermostatic mixing valve shall be installed to temper the water to a temperature of not greater than 140 degrees Fahrenheit for domestic uses.
5. Appliances and equipment used for heating water or storing hot water shall be protected by a separate pressure-relief valve and a separate temperature-relief valve, or a combination pressure-and-temperature relief valve. Check or shutoff valves shall not be installed between a relief valve and the termination point of the relief valve discharge pipe; between a relief valve and a tank; or between a relief valve and heating appliances or equipment.
6. Discharge piping serving a pressure-relief valve, temperature-relief valve or combination valve shall:
 - i. Not be directly connected to the drainage system.
 - ii. Discharge through an air gap located in the same room as the water heater.
 - iii. Not be smaller than the diameter of the outlet of the valve served and shall discharge full size to the air gap.
 - iv. Serve a single relief device and shall not connect to piping serving any other relief device or equipment.
 - v. Discharge to the floor, to the pan serving the water heater or storage tank, to a waste receptor or to the outdoors.
 - vi. Discharge in a manner that does not cause personal injury or structural damage.
 - vii. Discharge to a termination point that is readily observable by the building occupants.
 - viii. Not be trapped.
 - ix. Be installed to flow by gravity.
 - x. Terminate not more than 6 inches and not less than two times the discharge pipe diameter above the floor or waste receptor flood level rim.
 - xi. Not have a threaded connection at the end of the piping.
 - xii. Not have valves or tee fittings.
 - xiii. Be constructed of materials recognized by the plumbing code, such as CPVC plastic pipe, copper pipe, or PEX plastic tubing.
 - xiv. Be one nominal size larger than the size of the relief-valve outlet, where the relief-valve discharge piping is constructed of PEX or PE-RT tubing. The outlet end of such tubing shall be fastened in place.

ELECTRICAL

- a) All junction boxes shall remain accessible and shall not be concealed within walls or ceilings.
- b) Receptacles shall be of the grounding and tamper resistant type.
- c) Outdoor receptacles shall have an enclosure that is weatherproof both when an attachment is plugged in and when it is removed.
- d) All 120-volt, single phase, 15- and 20-ampere branch circuits supplying outlets installed in dwelling unit bedrooms shall be protected by a listed arc-fault circuit interrupter, combination type installed to provide protection of the branch circuit.

- e) A minimum of two 20-ampere-rated branch circuits shall be provided to serve all wall and floor receptacle outlets located in the kitchen, pantry, breakfast area, or dining area.
- f) The kitchen countertop receptacles shall be served by a minimum of two 20-ampere-rated branch circuits.
- g) Receptacles shall be provided for all unbroken wall spaces over 2 feet wide.
- h) Receptacles shall be located so that no point on the floor line is more than 6 feet measured horizontally from an outlet.
- i) Receptacles in bathrooms, kitchen counter or within 6 feet of sinks shall be GFCI protected.

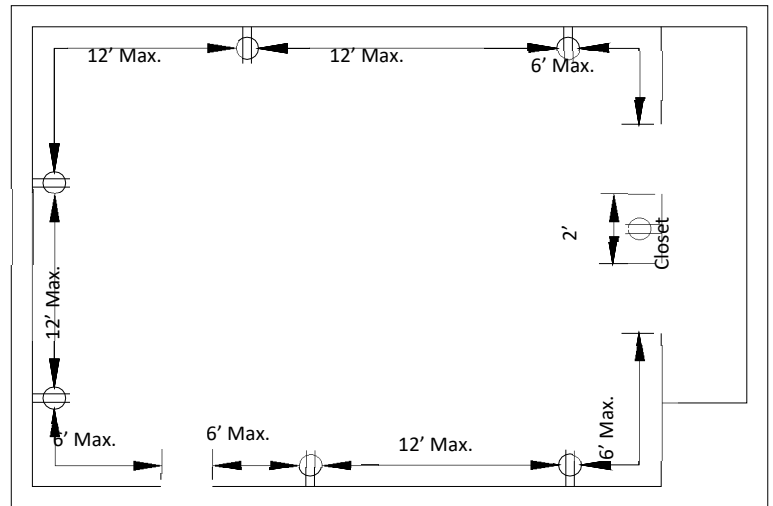
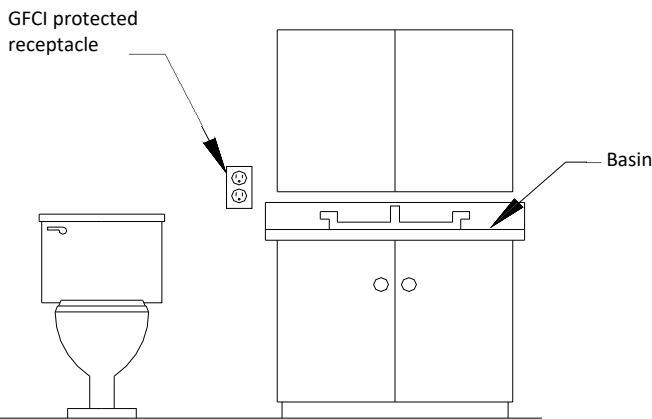

FINISHING

- a) Mechanical equipment set and connected.
- b) Energy certification. (3 or less air changes for blower door test, 70 or better using the Home Energy Rating System Index or HERS method).
- c) Water heater pan required, with 2" clear space between pan and water heater.
- d) Smoke detectors are required outside each sleeping area, in each sleeping room and on each floor level of the dwelling. Detectors shall be interconnected, receive their primary power from the building electrical system and shall be provided with battery backup.
- e) Carbon monoxide detector shall be installed outside of each separate sleeping area in dwelling units within which fuel-fired appliances are installed and in dwelling units that have attached garages.
- f) Stairway enclosures shall be protected by 1/2-inch gypsum board regardless if space is finished.
- g) Ceilings, including in unfinished spaces such as basements, shall be protected by 1/2-inch gypsum board where the framing consists of engineered lumber products or solid lumber less than 2"x10" nominal.
- h) Sump pit openings shall be sealed.
- i) Yard graded and free of debris.

