

# **Enhancing Broadband in Lawrence: A Range of Strategic Options**

**Prepared for the City of Lawrence, Kansas  
April 2013**

**Columbia Telecommunications Corporation**

10613 Concord Street • Kensington, MD 20895 • Tel: 301-933-1488 • Fax: 301-933-3340 • [www.ctcnet.us](http://www.ctcnet.us)

## Table of Contents

1.	Executive Summary .....	1
1.1	Project Background and Goals .....	1
1.2	Current State of Broadband Competition in Lawrence .....	2
1.3	Summary of Recommendations.....	4
2.	Technology Background: Fiber and Other Broadband Technologies.....	6
2.1	Wireline Architectures .....	6
2.1.1	Fiber-to-the-Premises.....	6
2.1.2	Hybrid Fiber–Coaxial Cable .....	10
2.1.3	Digital Subscriber Line .....	13
2.2	Wireless Architectures .....	14
2.2.1	“3G” and “4G” Technologies.....	14
2.2.2	Limitations of Existing Wireless Technologies .....	16
2.3	Other Technologies Are Not Capable of Speeds Enabled by Fiber .....	17
2.3.1	Fiber Holds Advantage over Copper/Coaxial Technologies .....	18
2.3.2	Fiber Holds Advantage over Wireless Technologies.....	20
3.	Current Broadband Offerings in Lawrence .....	22
4.	The Case for Focusing on Fiber In Lawrence.....	31
4.1	Fiber Represents the Preferred Medium for the Broadband Future.....	31
4.2	The Economic Development Impact of High-Capacity Broadband Is Growing.....	35
4.2.1	Kansas City .....	38
4.2.2	Chattanooga .....	39
4.2.3	International Research Paints a Strong Picture.....	39

4.3	Fiber Offers Significant Benefits to Public Safety Users .....	43
4.4	High-Capacity Broadband over Fiber Is Crucial for Community Anchor Institutions 43	
4.4.1	High Bandwidth Needs for Local Government.....	44
4.4.2	High Bandwidth Needs in Education .....	45
4.4.3	High Bandwidth Needs Among Libraries .....	53
4.4.4	High Bandwidth Needs in the Health Care Sector.....	58
4.5	The Residential Market Increasingly Requires High Capacity.....	67
5.	Potential Strategy 1: Continue and Enhance Current City Fiber and Conduit Projects	73
5.1	Background Regarding Existing City Conduit and Fiber Projects .....	73
5.2	Background on Municipal Fiber Networks for Internal Use.....	73
5.3	To Expand Its Footprint, Lawrence Should Take a Coordinated Approach to Installing Conduit.....	74
5.4	To Make Its Conduit Future-Proof, Lawrence Should Use a Robust Specification with Flexibility to Add Fiber in the Future.....	77
5.5	To Prepare for Future Fiber-to-the-Premises, Lawrence Can Require Fiber-Readiness in Greenfield and Reconstruction Areas .....	78
5.6	To Maximize Citywide Opportunities for Interconnectedness, Lawrence Should Secure Space in KU’s Network Operations Center .....	80
5.7	To Maximize Its Construction Resources, Lawrence Should Prioritize Cost-Effectiveness, Efficiency, and Economic Development Impact.....	80
5.8	To Capture Infrastructure Opportunities, Lawrence Should Establish Public Sector Working Groups.....	80
6.	Potential Strategy 2: Complete Fiber Rings Where Possible During the Course of Routine Fiber and Conduit Installation .....	82
7.	Potential Strategy 3: Lease Access to Excess City Fiber and Conduit .....	87
7.1	Business Model Background .....	87

7.2	Recommended Strategy and Risk Analysis .....	87
8.	Potential Strategy 4: Open The Lawrence Market to New Competition and Collaboration by Building an Internet Point-of-Presence.....	90
9.	Potential Strategy 5: Make Available to Local Businesses Information About Competitive Service Options .....	93
10.	Potential Strategy 6: Beware of Claims That Expediting Local Processes and Reducing Fees Will Solve Broadband Needs .....	95
11.	Potential Strategy 7: Proceed with Caution in Considering Municipal Fiber-to-the-Premises .....	97
11.1	Incumbent FTTP Background .....	98
11.2	Municipal FTTP Background .....	99
11.3	Lawrence FTTP Network Model.....	100
11.4	FTTP Financial Model.....	103
11.5	Next Steps for FTTP.....	105
12.	Strategy 8: Work with KU to Join Gig.U to Potentially Attract FTTP Investment .....	106
12.1	Background Regarding Gig.U.....	106
12.2	New Private Investment in Robust Fiber Networks Has Emerged in Response to Google and the Gig.U Effort.....	107
12.3	New City Initiatives Are Emerging to Seek Partnerships with New Investors ..	108
13.	Strategy 9: Leverage the City's Proximity to Kansas City and Communicate With Google	109
13.1	Google's Business Model .....	110
13.2	The City Should Establish Contact with Google in Follow-Up to CTC's Contacts	112

## Table of Figures

Figure 1: Sample FTTP Network .....	8
Figure 2: Sample DOCSIS 3.0 Network .....	11
Figure 3: National Broadband Map Data—Lawrence Availability vs. Nationwide .....	23
Figure 4: National Broadband Map Data—Broadband Speeds Available to City Residents.	24
Figure 5: National Broadband Map Data—Community Anchor Institutions Connected .....	25
Figure 6: National Broadband Map—Number of Providers Available.....	26
Figure 7: Kansas Broadband Map—Asymmetric DSL Coverage in Lawrence .....	26
Figure 8: Kansas Broadband Map—Cable DOCSIS 3.0 Coverage in Lawrence .....	27
Figure 9: Fiber Capacity Compared to Other Broadband Technologies .....	32
Figure 10: Networking Upgrades Needed for Online Assessments .....	49
Figure 11: Download Speeds for Libraries .....	54
Figure 12: Public Library Internet Connectivity Speeds (2011–2012) .....	56
Figure 13: Percentage of Office-Based Physicians with Electronic Medical Records.....	62
Figure 14: Long-Term Conduit Installation Strategy .....	77
Figure 15: Illustration of Value Presented by Larger Conduit .....	78
Figure 16: High-Level Diagram of Redundant Fiber Network .....	83
Figure 17: Multiple Survivable Paths from Redundant Fiber Connections.....	83
Figure 18: Map of Potential Fiber and Conduit Network Rings .....	84
Figure 19: Internet Point-of-Presence Would Create Valuable Connection for Lawrence ...	90
Figure 20: Configuration of Lawrence POP Facility.....	92
Figure 21: Comparative Speeds of Various Technologies.....	94
Figure 22: FTTP Hub Design.....	101
Figure 23: FTTP Distribution Design.....	102

## Table of Tables

Table 1: Typical Performance for Advertised 2G/3G/4G Services.....	15
Table 2: National Broadband Map Data—Broadband Providers in Lawrence.....	23
Table 3: Wireline Broadband Service Summary—Lawrence .....	27
Table 4: Wireline Broadband Service Summary—Champaign-Urbana, IL .....	28
Table 5: Wireline Broadband Service Summary—Madison, WI.....	29
Table 6: Wireline Broadband Service Summary—Ann Arbor, MI .....	29
Table 7: Typical Applications and Their Performance over Various Download/Upload Broadband Speeds (Single User).....	33
Table 8: Recommended Bandwidth for Schools .....	46
Table 9: Bandwidth Required to Achieve Full Functionality of Health IT Applications.....	58
Table 10: Network Characteristics of Telehealth Applications .....	65
Table 11: High-Level FTTP Cost Estimate.....	103

## 1. EXECUTIVE SUMMARY

### 1.1 PROJECT BACKGROUND AND GOALS

This report presents a range of strategic alternatives for the City of Lawrence to consider as it seeks to use advanced communications infrastructure to promote economic development and to ensure that broadband infrastructure in Lawrence meet the needs of its residents, businesses, and public institutions.

The City has incrementally and successfully built fiber and conduit for a number of years. This study focuses on identifying how Lawrence can maximize its current assets to encourage future technology development. It analyzes the existing communications environment in Lawrence and provides recommendations with respect to various options to leverage the City's existing fiber optic infrastructure, including:

1. Options for optimizing the benefits of existing City infrastructure
2. Options for expanding existing City infrastructure, both incrementally and very extensively
3. Options for potentially facilitating private construction and operations of broadband infrastructure

The study was researched and prepared in March and April 2013 by CTC Technology & Energy (CTC). Over the course of the engagement, CTC performed the following general tasks:

1. Met with key public stakeholders, including representatives of many City agencies, the University of Kansas (KU), the State of Kansas, and Lawrence Public Schools
2. Met or spoke with private stakeholders, including local businesses, local power utilities, interested entrepreneurs, and private schools and universities
3. Met with City stakeholders and the committee overseeing this project to present data, solicit input, and answer questions
4. Met with or spoke with a range of potential private sector partners from both the incumbent and competitive sides of the telecommunications/broadband industries, including Wicked Broadband, Knology, AT&T, Level 3, Google, and CenturyLink

5. Evaluated the current demand for broadband communications products and services in the City through a range of efforts and methodologies, including conversations with broadband providers in the City regarding the demand for, and adoption of, their products
6. Researched and evaluated the current supply of broadband communications products and services in the City through a range of efforts and methodologies:
  - a. Evaluated the relevant portions of the Kansas Broadband Map and National Broadband Map that are collected by the Kansas Statewide Broadband Initiative (Kansas Department of Commerce) and published both by the State of Kansas and by the federal government (Federal Communications Commission and U.S. Department of Commerce)
  - b. Conducted discussions with project stakeholders, including Lawrence businesses, many of whom indicate that their broadband needs are currently unmet
7. Developed recommendations regarding how the City can use its existing fiber to potentially stimulate or catalyze broadband investment in Lawrence
8. Developed recommendations regarding opportunities for the City to make incremental strategic investments in expanding broadband infrastructure as a means of enabling expansion of private sector broadband offerings and competition
9. Developed a preliminary engineering and financial analysis of requirements for deploying a fiber-to-the-premises (FTTP) broadband network across the City

## 1.2 CURRENT STATE OF BROADBAND COMPETITION IN LAWRENCE

Our research regarding broadband supply suggests that broadband is universally available in the City, but that on the whole, the residential and small business service offerings are costlier, slower, and more limited than in other comparable communities. (See Section 3.)

We also find that the consumer markets—residential and business—do not have access to the very high speeds that are enabled over fiber optics and that are increasingly viewed as the emerging international standard. Google’s fiber-to-the-premises (FTTP) deployment in Kansas City, for example, will provide gigabit (1,000 megabit) speeds, which is an order of magnitude higher than is available to most Americans but comparable to the speeds increasingly available in our competitor nations in Asia and some parts of Europe.



Knology operates a hybrid fiber/coaxial (HFC) system that can compete against other offerings in today's marketplace. Its network, however, is limited by its lack of fiber to every home and business—even with advanced electronics and software, its system cannot keep pace with the potential speeds of fully-fiber networks such as that in Kansas City. Cable systems are limited by the inherent shortcomings of the coaxial cable that runs from their nodes into the home. An additional limitation arises from the shared nature of cable modem service—bandwidth within a neighborhood is shared rather than dedicated. As a result, speeds may be significantly decreased by one's neighbors' simultaneous use of their cable modems.

Knology is an important provider in Lawrence, and many of the businesses we spoke to use its services, as do the major community institutions such as the schools. In one area of concern, many businesses report concerns with Knology's customer service, which they felt was better in the era when the company was locally owned by Sunflower.

AT&T is the incumbent local exchange carrier in Lawrence, where it offers digital subscriber line (DSL) services to most of the City and leases enhanced circuits to businesses at higher prices. Small and medium-sized businesses may have difficulty affording these enhanced circuits. AT&T has deployed U-Verse, its enhanced DSL product, in parts of Lawrence. (Spot-checks of residential addresses in Lawrence confirm this, though the National Broadband Map, in its current online version, omits that service availability because its data are not up to date.)

DSL represents a relatively low-bandwidth form of broadband—a network of roads, not superhighways. DSL runs on telephone network copper wires, which simply cannot handle the same capacity as fiber or even as HFC networks. As capacity requirements increase, DSL is likely to fall further behind cable.<sup>1</sup>

Even with newer DSL investments, its limitations are likely quickly to be reached. From a technical standpoint, DSL is a short-term solution in a market where bandwidth needs are growing exponentially and high, symmetrical capacity is increasingly needed for small businesses and for popular applications like gaming, video downloads, and video-conferencing. Aging copper plant is not capable of meeting these needs in the medium or long-run.

We also note the welcome presence of small, entrepreneurial providers offering fixed wireless in Lawrence, which offer a needed infusion of competition but do not provide

---

<sup>1</sup> The limitations of DSL are illustrated Verizon's investment, over the past decade, to supplement its old copper phone networks with new FTTP networks in limited metropolitan areas within its existing footprint.

robust competition for wireline services other than where they are able to serve customers over fiber optics.

With respect to mobile wireless services, we find that Lawrence is receiving comparable state-of-the-art services to other regions of the country, but that such services serve as a complement—not an alternative—to robust fixed services such as fiber-to-the-premises. AT&T, Sprint, and Verizon Wireless have deployed 4G LTE services in Lawrence, while T-Mobile offers 3G service. According to the National Broadband Map, 100 percent of Lawrence residents have access to broadband wireless service.

Importantly, however, mobile does not supplant or compete with wireline broadband; rather, these technologies inherently serve to enhance and complement each other. Fiber offers highly scalable bandwidth while wireless is limited by available spectrum. Relative to fiber, wireless also offers lower speeds that cannot support some of the ultra-high speed applications made possible by fiber in the areas of business, health care, and education. Wireless services are also typically more expensive on a monthly basis, and become even more costly if users have prepaid or non-contract usage, or if they exceed their monthly data allowances (i.e., data caps)—meaning that heavy users (especially home-based businesses) are essentially unable to use AT&T or Verizon Wireless mobile connections as their primary broadband connection. At the same time, however, fiber cannot mirror a wireless connection’s key advantage: Wireless offers mobility and enables users to stay connected virtually anywhere they go.

### 1.3 SUMMARY OF RECOMMENDATIONS

The City has completed an impressive roster of fiber infrastructure projects over more than 15 years, from the fiber backbone installed in City Hall in 1997 to a number of outside plant fiber extensions this year.<sup>2</sup> (CTC applauds the City for the cooperative way in which its departments work together—particularly IT and Public Works, but other departments as well—and their close work with the City Manager’s office. We have been impressed at the degree to which silos have been broken down, which is not always common within comparably sized communities.)

The City’s IT Department has also developed a range of creative and entrepreneurial partnerships—including with the University of Kansas and Douglas County—which the City has capitalized on for mutually beneficial infrastructure deployment. Looking to the future, the City is contemplating a number of important projects that the IT Department

---

<sup>2</sup> These projects are documented in the “Fiber Projects Overview” report prepared by Mr. James Wisdom, Director of the City’s Information Technology Department, and dated March 2013.

has researched and developed, including additional projects with KU and the County, and potential fiber partnerships with community anchor institutions (CAI) such as Lawrence Memorial Hospital, Lawrence Public Library, and Lawrence Public Schools.<sup>3</sup>

We recommend pursuing all of these proposed projects. The City's strategists have done an exceptional job of planning cost-effective, efficient, and low-risk infrastructure initiatives that would be mutually beneficial for the City and the potential partners.

Along with these well-conceived projects, we considered a range of additional strategies that would leverage the City's existing assets to promote further infrastructure development and expansion. We summarize these strategies here, and describe them in greater detail in Sections 5 through 13:

- Take a coordinated approach to installing conduit
- Require conduit and fiber installation for new construction
- Develop a robust specification for conduit that offers flexibility to add new conduit in the future
- Complete fiber rings where possible during the course of routine fiber and conduit installation
- Implement an Internet point-of-presence
- Build fiber as the opportunity arises to key economic development targets
- Lease access to existing fiber and conduit to enable private competition and investment
- Educate local businesses about service options
- Proceed with caution in considering municipal fiber-to-the-premises strategies
- Work with KU to join Gig.U as a means of engaging private investors in fiber-to-the-premises networks
- Establish contact with Google and other providers now considering fiber-to-the-premises investments

---

<sup>3</sup> Ibid.

## 2. TECHNOLOGY BACKGROUND: FIBER AND OTHER BROADBAND TECHNOLOGIES

This section summarizes the current status of fiber and other broadband technologies, as they have been deployed by the communications industry in the United States, and discusses the inherent advantages fiber holds over other technologies.

### 2.1 WIRELINE ARCHITECTURES

The wireline component is typically the highest-speed portion of a network. Where it is part of a wireless/mobile network, wireline communications provide the backbone between key network locations and the interface with the wireless network (i.e., the base stations or cell sites). The majority of homes and businesses nationwide are connected via wireline communications, and the role of the wireline connection has evolved to provide users' most intensive needs—high-definition television, telecommuting applications, telemedicine, gaming, data backup, digital media storage and transport, and “cloud” applications.

There are three primary modes of wireline communications:

- 1) Fiber-to-the-premises (FTTP), adopted by Verizon in some markets
- 2) Hybrid fiber-coaxial (HFC), used by Knology, Comcast, and other cable operators
- 3) Digital subscriber line (DSL) used by AT&T over its copper telephone lines

#### 2.1.1 FIBER-TO-THE-PREMISES

Since the early 1990s, telecommunications and broadband operators have deployed wireline networks consisting of their legacy infrastructures (copper or coaxial), and the core, backbone, and long-haul components using fiber optic technology. Over that time the providers have expanded the fiber component from the core, to reach closer to the home and business.

Fiber-to-the-premises (FTTP) provides the greatest capacity, reliability, and flexibility of all wireline solutions and is therefore the state-of-the-art wireline transport technology. Fiber itself provides a broad communications spectrum and has a theoretical capacity of hundreds of Gbps per fiber with off-the-shelf equipment; even low-priced equipment can provide 1 Gbps.

Because it contains no metal components, fiber is not susceptible to interference from outside signals or to corrosion. Fiber installed 20 years ago is not physically or technologically obsolete.

Fiber optic equipment generally has a range of 12 miles with standard passive optical network (PON) electronics<sup>4</sup> and almost 50 miles with higher-powered electronics.<sup>5</sup> The range reduces or eliminates the need for electronics or powering in the middle of the network, reducing the network's required staffing and maintenance and improving availability during storms or mass power outages.<sup>6</sup> Fiber can be continuously upgraded simply by replacing or upgrading the network electronics at the ends.

Figure 1 illustrates a sample FTTP network, demonstrating how high levels of capacity and reliability are brought directly to the premises—providing connectivity without a technical bottleneck to the Internet or other service providers, and providing a flexible, high-speed backbone for wireless services.

---

<sup>4</sup> ITU-T Recommendation G.984.2 Gigabit-capable Passive Optical Networks (GPON): Physical Media Dependent (PMD) layer spec., p. 10, Table 2a, <http://www.itu.int/rec/T-REC-G.984.2-200303-I/en>.

<sup>5</sup> Cisco Small Form-Factor Pluggable Modules for Gigabit Ethernet, [http://www.cisco.com/en/US/prod/collateral/modules/ps5455/ps6577/product\\_data\\_sheet0900aecd8033f885.pdf](http://www.cisco.com/en/US/prod/collateral/modules/ps5455/ps6577/product_data_sheet0900aecd8033f885.pdf).

<sup>6</sup> Powering is required at the central office facility (usually equipped with long-running generators) and at the user premises (requiring the user to have backup power, such as a battery or a home generator). In contrast, hybrid fiber-coaxial networks have power supplies in each neighborhood with a few hours of battery backup. Once the batteries are depleted, the cable operator must place a generator at each power supply location.

Figure 1: Sample FTTP Network

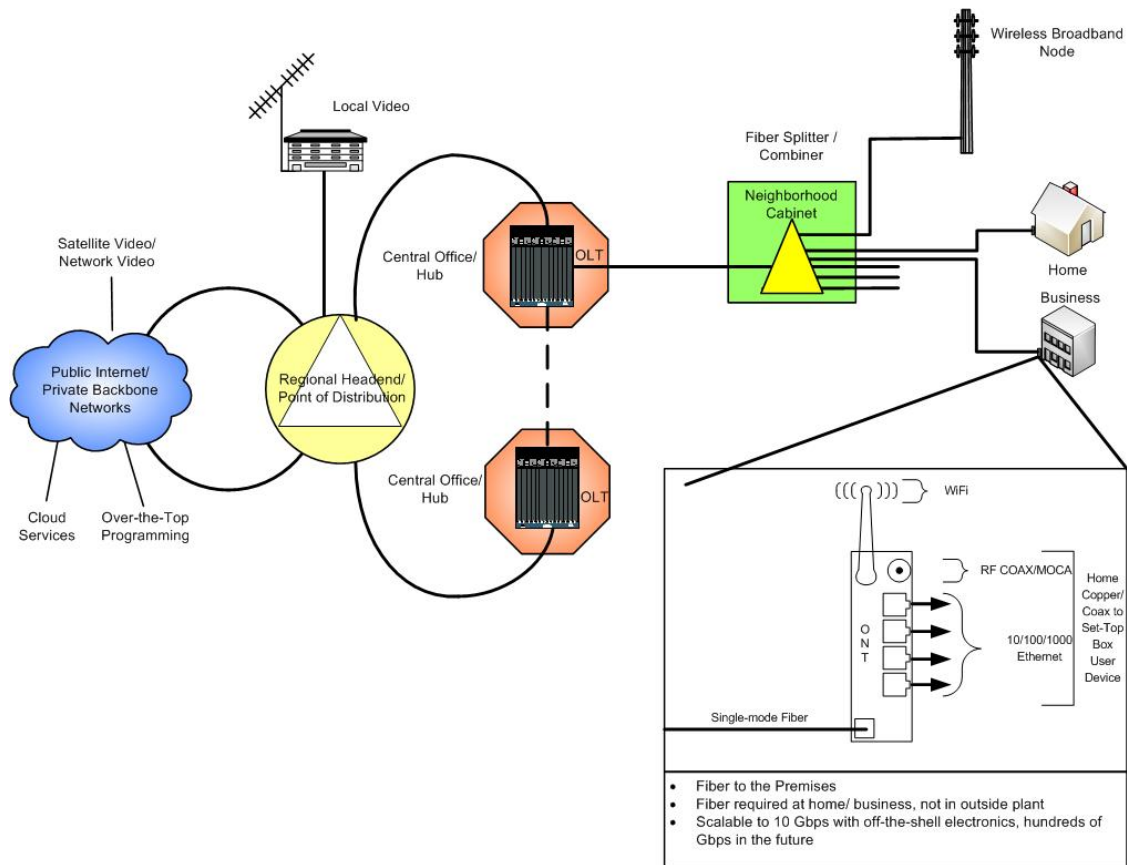

### 2.1.1.1 International FTTP

Internationally, FTTP is increasingly common, sometimes initiated by private sector companies, sometimes initiated or mandated by governments. In the Asia-Pacific region, in particular, almost every developed country that competes with the United States in the global economy has a national plan and funding mechanism to build next-generation networks. In Australia, for example, the government will build, own, and operate a fiber optic network to nearly every home and business in the country. In New Zealand, the government is innovatively financing construction (by Telecom New Zealand in some parts of the country, and public power in other parts) of a FTTP network that will eventually reach 75 percent of the population; LTE (4G) wireless service will reach the most rural 25 percent. (The entity representing the New Zealand government in this regard has also required Telecom New Zealand to divest its retail service arm, so that infrastructure ownership and service provision are separate, and the infrastructure owner has no

incentive to prefer or prioritize its services or content over those of the many service layer competitors.)

In Japan, the central government funded construction of an FTTP network by the private telecom (phone company), but required an open access business model. In Singapore, the government funded construction of ubiquitous FTTP and partnered with a French company, Axia NetMedia, to operate the system.

In Europe, government funding has been somewhat less aggressive, but still very significant. The French government has long offered grants and very low cost loans to providers that will build FTTP in rural areas. Multiple French municipalities have built their own municipal FTTP networks and contracted with private sector partners to operate the networks. In Ireland, the central government has offered loan/grant combinations to county governments that are willing to build middle-mile fiber to key commercial locations and anchor institutions, with the Irish government taking most of the risk in the event of financial challenges to the model.

In Scandinavia, municipalities have been extremely aggressive in constructing fiber both for government and commercial use. Sweden, which has been a leader both in the number of projects and the innovation of the business models, has more than 200 localities that own or operate some level of fiber.

#### **2.1.1.2 FTTP in the United States**

By the late 2000s, Verizon began constructing fiber optics all the way to homes and businesses in selected markets nationwide. This technology now reaches more than 15 million customers under the brand name FiOS.<sup>7</sup> In other parts of the United States, municipal operators and telephone cooperatives have also constructed FTTP networks.

Verizon is providing data, video, and voice services with a maximum offered speed of 300 Mbps download, 65 Mbps upload.<sup>8</sup> However, the fiber in the Verizon FTTP network could scale to significantly higher speeds. With the Gigabit Passive Optical Network (GPON) electronics Verizon is currently deploying, each 36-user segment of the network shares 2.4 Gbps of downstream capacity and 1.2 Gbps of upstream capacity; assuming 50 percent penetration, this can provide on average a 133 Mbps committed speed per user and 66 Mbps upstream—with burst capacity significantly higher. The next generation upgrade is 10G GPON technology (10 Gbps downstream, 2.4 Gbps upstream), which is under test by

---

<sup>7</sup> Previously the only premises to receive fiber optics were those receiving the highest-speed business services, such as DS3 (45 Mbps) or greater symmetrical services.

<sup>8</sup> “FiOS Internet Speed Comparison Tool,” Verizon website, <http://www22.verizon.com/home/fios-fastest-internet/>.

Verizon and deployed for trial users in the Singapore OpenNet.<sup>9</sup> When required by customer demand, the operator can activate the 10G GPON on the same fiber as the current GPON, requiring no new outside plant electronics and creating no disruption on the existing network. Future possibilities include wavelength division multiplexing (WDM) solutions with 10 to 100 times the capacity of 10G GPON (again, not requiring a rebuild of the fiber network outside plant).

Although Verizon offers the fastest mass-deployed service in some U.S. communities, it is—as Google’s fiber project in Kansas City illustrates—moving considerably more slowly than the FTTP technology permits. Hong Kong Broadband Network (HKBN) and the Chattanooga, Tennessee Electric Power Board (EPB) are also offering 1 Gbps using FTTP technology.<sup>10</sup> Verizon’s engineers have stated publicly that the service levels offered were a matter of business decisions based on what Verizon thought the market would pay for, rather than any technical limitations. Verizon representatives have stated in private meetings that the company anticipates offering 1 Gbps service on its FiOS network by 2017.<sup>11</sup>

### *2.1.2 HYBRID FIBER–COAXIAL CABLE*

Cable operators, including Knology, have extended fiber optics progressively closer to their subscribers’ premises but have generally stopped about one mile from the premises, using coaxial cable for the last mile. Thus, their networks are a hybrid of fiber and coaxial infrastructure. Knology typically only constructs fiber optics on a custom basis to the premises of businesses that subscribe to Metro Ethernet and other advanced services (i.e., generally faster than 50 Mbps).

Cable operators have discussed constructing fiber optics to the premises, starting with new greenfield developments, but so far have generally not done so. They have typically opted instead to install new coaxial cables to new users, even though the construction cost to new premises is approximately the same.

In Lawrence, Knology offers services using HFC technology. This is the dominant type of wireline broadband service in the City. According to the National Broadband Map, Knology

---

<sup>9</sup> Other fiber technologies include WDM PON, which assigns separate wavelengths of light to separate users (a deployment is currently underway in South Korea), and point-to-point fiber networks, such as the Citynet in Amsterdam, with individual users each receiving separate dedicated fibers.

<sup>10</sup> HKBN bb1000 description, [http://www.hkbn.net/2010/eng/en\\_service1\\_1a5.html](http://www.hkbn.net/2010/eng/en_service1_1a5.html), HKBN pricing from \$27 Gigabit At Hong Kong Broadband, <http://www.dslprime.com/fiber-news/175-d/2878-27-gigabit-at-hong-kong-broadband>; Your Gig is Here, <http://www.chattanoogagig.com>; Chattanooga pricing at approximately \$350, <https://epbfi.com/you-pick/#/fi-tv-essential&fi-speed-internet-30>.

<sup>11</sup> As recounted by Joanne Hovis, President, CTC.



uses the current leading cable technology for broadband, known as Data over Cable System Interface Specification version 3.0 (DOCSIS 3.0). DOCSIS 3.0 makes it possible for cable operators to increase capacity relative to earlier cable technologies by bonding multiple channels together. The DOCSIS 3.0 standard requires that cable modems bond at least four channels, for connection speeds of up to 200 Mbps downstream and 108 Mbps upstream (assuming use of four channels in each direction). A cable operator can carry more capacity by bonding more channels.

Figure 2 (below) illustrates a sample DOCSIS 3.0 network architecture.

Figure 2: Sample DOCSIS 3.0 Network

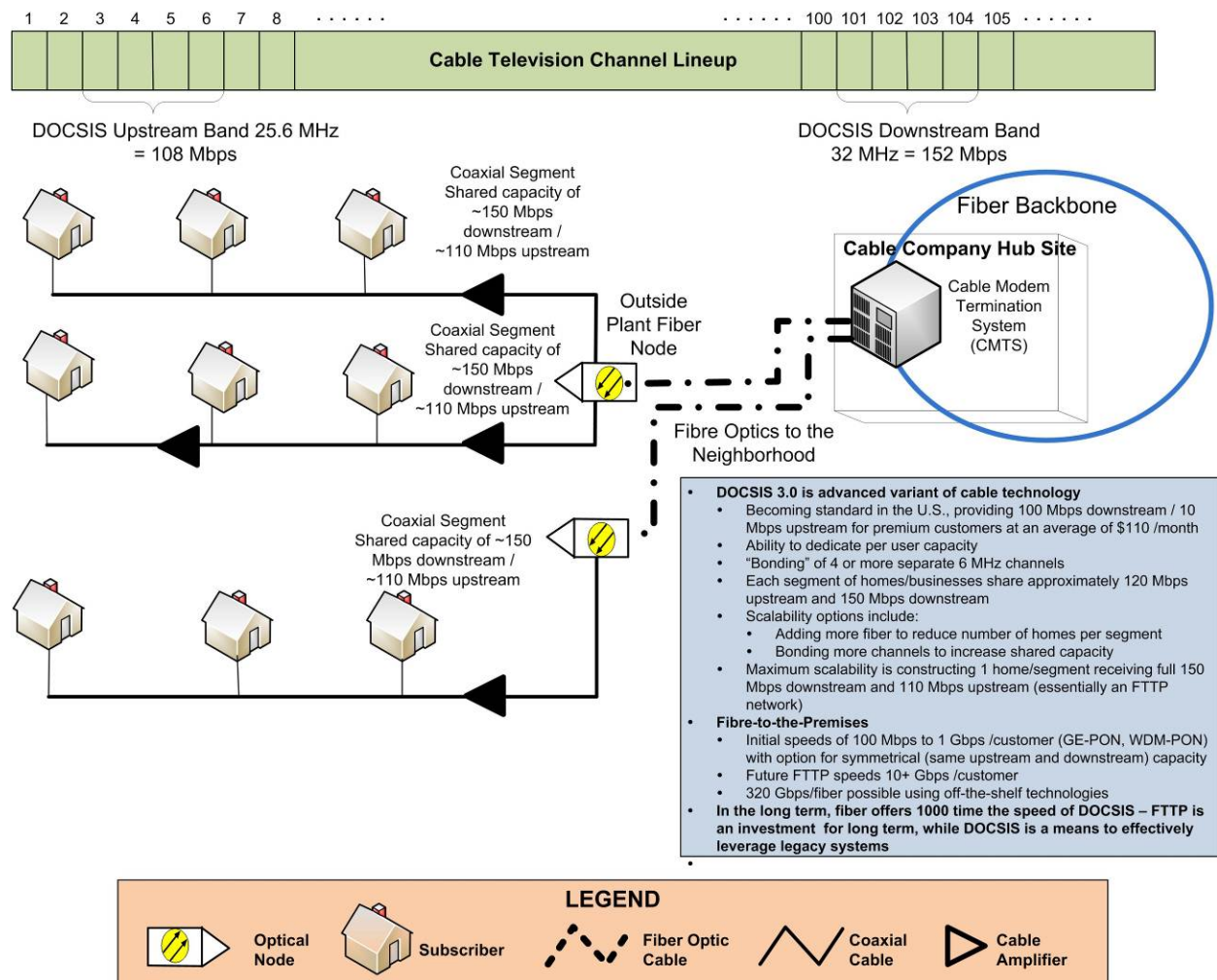

Ultimately, the maximum speed over an HFC network is limited by the physics of the cable plant; although an HFC network has fiber within certain portions of the network, the

coaxial connection to the customer is generally limited to less than 1 GHz of usable spectrum in total. By comparison, the capacity of fiber optic cable is orders of magnitude greater and is limited, for all intents and purposes, only by the electronic equipment connected to it—allowing for virtually limitless scalability into the future by simply upgrading the network electronics.

Theoretically, there is significant room for upgrading the speeds in a cable system, especially if there is access to high speed fiber optic backbone. For example, Virgin Mobile is offering 1.5 Gbps service in Britain over a cable network, presumably by bonding more than 30 channels.<sup>12</sup> It is critical to note that these are peak speeds, and that the capacity is shared by all customers on a particular segment of coaxial cable; this is typically hundreds of homes or businesses.

The cable industry is now actively developing the DOCSIS 3.1 standard, which will make it possible to:

1. Aggregate the available capacity on the system into larger, more usable blocks rather than 6 MHz television channels,
2. Have larger upstream capacity,
3. Increase the capacity and flexibility of the system without necessitating additional fiber construction, and
4. Create an architecture consistent with migrating the non-IP traffic (i.e., TV channels) to an IP format.

DOCSIS 3.1 is an evolution of DOCSIS 3.0 that uses an orthogonal frequency division multiplexing (OFDM) modulation scheme. This scheme, in which the aggregated IP traffic is spread over a large number of smaller subcarriers, allows the cable operator to move from the 6 MHz channels to much larger spectrum blocks. OFDM is used in DSL, LTE, and WiMAX technologies and allows the communications medium to use large spectrum blocks while effectively and adaptively managing noise and other issues that may emerge.

DOCSIS 3.1 also reallocates the spectrum balance between upstream and downstream directions, so that, with modifications in the amplifiers and other components of the cable system, a larger amount of spectrum is allocated to upstream traffic.

---

<sup>12</sup> Speed is claimed in advertising but no independent verification is available. Also, there is no description of the burst vs. guaranteed speed or the symmetry (upstream/downstream) of the service. See, for example: Beach, Jamie, "Virgin Media trials 1.5 Gbps speeds using DOCSIS 3.0," *telecoms.com*, Sept. 14, 2011. <http://www.telecoms.com/32896/virgin-media-trials-1-5-gbps-speeds-using-docsis-3-0/>.

From the standpoint of spectral efficiency (Mbps carried per MHz) DOCSIS 3.1 is comparable to 3.0. Therefore a DOCSIS 3.1 system will carry approximately the same order of magnitude of capacity as a system with several bundled DOCSIS 3.0 channels (i.e., the Virgin Mobile system discussed above) but can be managed more efficiently and with more symmetrical (up and downstream) capacity.

Industry claims are that DOCSIS 3.1 carries 10 Gbps downstream capacity. This will not be possible for most actual cable systems—a typical system with 860 MHz capacity will have the first 200 to 250 MHz assigned to upstream, leaving 600 to 650 MHz for downstream. With 10 bps/Hz efficiency, the actual capacity for a shared node area will be closer to 6 Gbps than 10 Gbps, and the capacity will be shared among a few hundred users—but it will still be a significant improvement over most current cable systems. With appropriate planning and node segmentation, it should be possible to regularly deliver more than 100 Mbps to customers on a consistent and steady basis and to fully migrate the television system to IP technology, if desired.<sup>13</sup>

### 2.1.3 DIGITAL SUBSCRIBER LINE

Copper “twisted-pair” telephone lines remain the main wireline communications medium globally, and considerable effort has gone into extending the capabilities and capacity of these lines. Digital Subscriber Line (DSL) technology expands the capacity of twisted-pair copper lines to provide higher-speed service.

Retail providers selling DSL services on copper lines deliver a maximum speed that depends on the proximity of the central office or cabinet to the customer premises.<sup>14</sup>

Copper telephone lines are used to provide DSL services. The DSL service area is limited by the availability in the AT&T central offices or remote cabinets, the condition of the copper wires, and the distance from the central office. The available speed varies on a case-by-case basis, depending on the above factors. Usually a DSL customer needs to be within three or four miles of a central office or cabinet.

In the United States, AT&T is a major DSL provider. AT&T also offers a service it calls U-verse in some areas, apparently including Lawrence.<sup>15</sup> U-verse utilizes additional fiber to

---

<sup>13</sup> “Docsis 3.1 Targets 10-Gig Downstream,” *Lightreading*, October 18, 2012,

<http://www.lightreading.com/docsis/docsis-31-targets-10gig-downstream/240135193>.

<sup>14</sup> The performance and maximum capacity of DSL on a copper telephone line depends on the frequency response of the individual line, which in turn depends on the condition and length of the line.

<sup>15</sup> Our research indicated U-verse was available at some sample addresses throughout the City. The National Broadband Map and Kansas Broadband Maps identify AT&T as a DSL provider and mobile wireless provider only.

increase broadband capacity over the DSL network.<sup>16</sup> The maximum offered data speed of U-verse is 24 Mbps, with additional capacity for video traffic.<sup>17</sup> Video and voice are provided in Internet Protocol (IP) format, requiring IP set-top converters for all voice and video services.

## 2.2 WIRELESS ARCHITECTURES

With the improvement of the quality and speed of wireless communications, the public has become accustomed to using Internet services with wireless technologies, either on a communications link managed by a wireless service provider (i.e., a cellular data plan), on local infrastructure typically managed at a home or business (i.e., a WiFi hotspot), or through a mixture of those two approaches, in which an entity such as a service provider, municipality, landlord, or homeowners association operates a hotspot-oriented infrastructure.

### 2.2.1 "3G" AND "4G" TECHNOLOGIES

For some consumers, even those who receive wireline service to their homes or businesses, their primary contact with the Internet is through their smartphone or wireless-equipped tablet or laptop computer. Nationwide, wireless providers operate a mixture of third-generation (3G) and emerging fourth-generation (4G) technologies. The service providers typically provide devices (telephones, smartphones, air cards, tablet computers) bundled with 3G or 4G services. Typically devices are not portable from carrier to carrier, because they are "locked" into the carrier by software and/or because differences in the technologies used by the carriers limits compatibility of the devices (discussed below). As a result, the purchase of a device is a de facto commitment to a particular service provider, as long as the user uses the device.

---

<sup>16</sup> AT&T's U-verse dissected, <http://adslm.dohrenburg.net/uverse/>.

<sup>17</sup> AT&T U-verse High Speed Internet, <http://www.att.com/u-verse/explore/internet-landing.jsp?fbid=regRwrVqL4d>.

**Table 1: Typical Performance for Advertised 2G/3G/4G Services**

Applications	Technology (Download/Upload Service Speeds) <sup>18</sup>		
	2G/2.5G-EDGE/GPRS, 1xRTT (128 Kbps-300 Kbps/ 70 Kbps-100 Kbps)	3G-EVDO Rev A, HSPA+ (600 Kbps-1.5 Mbps/500 Kbps-1.2 Mbps)	4G - WiMAX/ LTE (1.5 Mbps-6 Mbps/500 Kbps-1.2 Mbps)
Simple text e-mails without attachments (50 KB)	Good (2 seconds)	Good (1 second)	Good (1 second)
Web browsing	Good	Good	Good
E-mail with large attachments or graphics (500 KB)	OK (14 seconds)	Good (3 seconds)	Good (1 second)
Play MP3 music files (5 MB)	Bad (134 seconds)	OK (27 seconds)	Good (7 seconds)
Play video files (100 MB for a typical 10-min. YouTube video)	Bad (45 minutes)	OK (9 minutes)	Good (3 minutes)
Maps and GPS for smartphones	Bad	OK	Good
Internet for home	Bad	OK	Good

The strict definition of 4G from the International Telecommunications Union (ITU) was originally limited to networks capable of peak speeds of 100 Mbps to 1+ Gbps depending on the user environment;<sup>19</sup> according to that definition, 4G technologies<sup>20</sup> are not yet deployed.

In practice, a number of existing technologies (e.g., LTE Revision 8, WiMAX) are called 4G by the carriers that provide them and represent a speed increase over 3G technologies as well as a difference of architecture—more like a data cloud than a cellular telephone network overlaid with data services. Furthermore, a transition technology called HSPA+, an

<sup>18</sup> This data assumes a single user. For downloading small files up to 50 KB, it assumes that less than 5 seconds is good, 5-10 seconds is OK, and more than 10 seconds is bad. For downloading large files up to 500 KB, it assumes that less than 5 seconds is good, 5-15 seconds is OK, and more than 25 seconds is bad. For playing music, it assumes that less than 30 seconds is good, 30-60 seconds is OK, and more than 100 seconds is bad. For playing videos, it assumes that less than 5 minutes is good, 5-15 minutes is OK, and more than 15 minutes is bad.

<sup>19</sup> "Development of IMT-Advanced: The SMaRT approach," Stephen M. Blust, International Telecommunication Union.

<http://www.itu.int/itunews/manager/display.asp?lang=en&year=2008&issue=10&ipage=39&ext=html>

<sup>20</sup> Such as LTE Advanced, under development.

outgrowth of 3G GSM technology previously considered a 3G or 3.5G technology with less capability than LTE or WiMAX, has been marketed as “4G” by AT&T and T-Mobile, so the definition of 4G is now fairly diluted. The ITU and other expert groups have more or less accepted this.<sup>21</sup>

### *2.2.2 LIMITATIONS OF EXISTING WIRELESS TECHNOLOGIES*

It is critical to understand that wireless communications technologies are limited and will always provide less capability and flexibility than the wireline technologies available at a given moment in time. Wireless is limited by over-the-air spectrum (i.e., the “channels” used for the signals), by range, and by line-of-sight. When an individual views images or videos on a device such as an iPad or a wireless Roku set-top converter, the communications link has traveled through a fiber optic backhaul connection to a service provider’s base station (or to a home FTTP optical network terminal, cable modem, or DSL modem). From that point the signal travels either over a service provider network with careful signal and capacity modeling,<sup>22</sup> or from a hotspot located only a short distance from the user (and usually only serving the users in that premises).

Most consumers will therefore find that wireless broadband has technological limitations relative to wireline:

- 1) *Lower speeds.* At their peaks, today’s newest wireless technologies, WiMAX and LTE, provide only about one-tenth the speed available from FTTP and cable modems. In coming years LTE Advanced may be capable of offering Gbps speeds with optimum spectrum and a dense build-out of antennas—but even this will be shared with the users in a particular geographic area and can be surpassed by more advanced versions of wireline technologies (with Gbps speeds already provided by some FTTP providers today).
- 2) *More asymmetrical capacity, with uploads limited in speed.* As a result it is more difficult to share large files (e.g., video, data backup) over a wireless service, because these will take too long to transfer; it is also less feasible to use video conferencing or any other two-way real-time application that requires high bandwidth.

---

<sup>21</sup> “ITU softens on the definition of 4G mobile,” *NetworkWorld*, December 17, 2010.

<http://www.networkworld.com/news/2010/121710-itu-softens-on-the-definition.html>

<sup>22</sup> Despite the dedicated spectrum (channel capacity), detailed engineering, and continuous upgrades in technology, wireless providers face significant challenges meeting the demand of users with laptop/tablet and smartphone devices, and have implemented bandwidth limits and other measures to control and ration usage.

- 3) *Stricter bandwidth caps.* Most service providers limit usage more strictly than wireline services. Though wireless service providers may be able to increase these caps as their technologies improve, it is not clear whether the providers will keep ahead of demand. A *Washington Post* article about Apple's iPad with 4G connectivity highlighted the issue: "Users quickly are discovering the new iPad gobbles data from cellular networks at a monstrous rate. Some find their monthly allotment can be eaten up after watching a two-hour movie. That has left consumers with a dilemma: Pay up for more data or hold back on using the device's best features."<sup>23</sup>
- 4) *Limitations on applications.* For example, users of smartphones and some tablet computers are limited by service providers or device manufacturers to approved applications. Apple limits the applications that can operate on its iPhone and iPad devices. Although Android is an open platform, Verizon Wireless blocks uploads of video from Android wireless devices on its networks by disabling the feature unless the user is on a private WiFi network. The FCC has reiterated that wireless providers have almost unlimited latitude to manage usage on their networks, in effect applying network neutrality rules only to wired networks; service providers can therefore expand their "management" of applications beyond the devices they provide to blocking or slowing applications from users with aircard-equipped PCs or home networks. The 3GPP protocols underlying LTE and subsequent technologies are designed to enable service providers to manage capacity based on application type (i.e., to prioritize particular types of traffic and make others lower priority).

### 2.3 OTHER TECHNOLOGIES ARE NOT CAPABLE OF SPEEDS ENABLED BY FIBER

Fiber technology offers speeds and capacity that are several orders of magnitude removed from the other technologies that are considered to "compete" with it—as a technical matter and as a matter of physics, those technologies cannot compete with fiber:

A T-1 circuit, for example, is frequently the only "high" bandwidth option available to a small business over copper (and then at considerable cost); it offers 1.54 Mbps, or one 600<sup>th</sup> of the speed that fiber can deliver using existing, affordable, off-the-shelf technologies (Gigabit Ethernet, 1,000 times one megabit). These speeds will grow dramatically as new technologies become available. The speeds possible over copper, coax, and wireless speeds will also grow, but as a matter of physics, cannot keep up with fiber's ability to scale.

---

<sup>23</sup> Cecilia Kang, "New iPad users slowed by expensive 4G network rates," *Washington Post*, March 22, 2012. [http://www.washingtonpost.com/business/economy/new-ipad-users-slowed-by-expensive-4g-network-rates/2012/03/22/gIQARLXYUS\\_story.html?hpid=z2](http://www.washingtonpost.com/business/economy/new-ipad-users-slowed-by-expensive-4g-network-rates/2012/03/22/gIQARLXYUS_story.html?hpid=z2)

*Gigabit over fiber offers more than 25 times the maximum capacity of advanced cable networks,<sup>24</sup> more than 75 times the capacity of advanced copper/phone networks,<sup>25</sup> and 250 times the capacity of the fastest, most sophisticated commercial wireless services currently available to consumers on PDAs and laptops.<sup>26</sup>*

### *2.3.1 FIBER HOLDS ADVANTAGE OVER COPPER/COAXIAL TECHNOLOGIES*

Copper wire has been widely used for carrying voice, video, and data since the days of the telegraph. Progress in telecommunications technology and the growth in popularity of the Internet were characterized by a transition to digital modes of communications and higher demands for communications capacity. As a result, copper telecommunications networks were retrofitted for transferring data as well, with an ongoing shift in the network architectures to support the growing demands.

Copper cabling is predominantly found in two forms: coaxial (coax) cables and twisted-pair cables. Coax cables were originally used for carrying video signals within cable television systems and radio frequency (RF) signals to and from antennas within wireless systems. Twisted-pair copper wire was developed from the invention of the telegraph, and was later used in the traditional telephone industry. Due to rising demands for Internet connectivity, cable TV companies and traditional phone companies adapted their infrastructure with new technologies, including cable modems and digital subscriber line (DSL), to begin offering higher speed data services than simple telephone lines could support.

Coax cables, on the other hand, have one central conductor surrounded by a conductive shield that blocks electromagnetic interference (EMI) from outside sources. Insulating layers separate and protect each conductive component.

All copper cables use electrical signals to transfer information between users. Optical fibers use light rays to transfer the same information through their glass cores. The core is usually made out of specialized glass with low optical attenuation. The cladding, coating, and housing serve to protect the optical core and minimize the optical loss of the core.

Optical fibers and copper cables have different physical compositions, which give the optical fibers inherent advantages over their copper counterparts. For a given expenditure in communications hardware, fiber optics can reliably carry many times more capacity

---

<sup>24</sup> Assuming average downstream speeds of approximately 38 Mbps. Note that cable modem networks are usually engineered to enable far slower upstream speeds.

<sup>25</sup> Based on maximum downstream speeds on a VDSL network of approximately 13 Mbps with a maximum distance of 5,000 feet between the customer premises and provider Central Office. Note that DSL networks are usually engineered to enable far slower upstream speeds.

<sup>26</sup> Assuming average downstream speeds of 4 Mbps, currently available only in limited markets. Note that wireless networks are usually engineered to enable far slower upstream speeds.



over many times greater distances than copper wires of any type—far superior in both regards.

The biggest advantage that fiber has over copper is the exponentially greater bandwidth that it can provide. This bandwidth is only restricted by the electronics at either end of the cable; modern fiber equipment is capable of speeds on the order of terabits per second over a single “strand.” In addition, not only do fibers provide more bandwidth, they are able to do so over longer distances as compared to copper cables without necessitating regeneration or amplification, both of which can reduce signal reliability and capacity while increasing costs.

Bandwidth limits on copper cables are directly related to the underlying physical properties of copper. Copper conducts electrical signals at various frequencies, and higher data rates over copper require higher frequencies of operation. Twisted pair wire is limited to a few hundred megahertz in usable bandwidth (at most), with dramatic signal loss increasing with distance at higher frequencies. This physical limitation is why DSL service is only available within a close proximity to the telephone central office. Coaxial cable has a frequency bandwidth of approximately one gigahertz, or more; therefore its capacity is greater than that of twisted pair. Despite its higher capacity, coaxial cable does experience signal attenuation at higher frequencies similar to twisted pair. In other words, coaxial cable is incrementally more capable than twisted-pair wire, though it is still not comparable to the exponentially greater upper limits of fiber.

Within a fiber optic strand, an optical communications signal (essentially a ray of light) behaves according to a principle referred to as “Total Internal Reflection” that guides it through the optical cable. Optical cables do not use electrical conduction, and thus do not require a metallic conductor, such as copper, as their propagation medium. Further, technological innovations have allowed for the manufacturing of very high quality, low impurity glass that can provide extremely low losses within a wide range of frequencies, or wavelengths, of transmitted optical signals, enabling long range transmissions. Compared to a signal loss on the order of tens of decibels (dB) over hundreds of feet of coaxial cable, a fiber optic cable can carry a signal of equivalent capacity over several miles with only a few tenths of a dB in signal loss.

Even with technological advances, copper cables will not be able to live up to customer requirements. This is why communications carriers and cable operators are deploying fiber to replace large portions of their copper networks, and on an increasingly larger scale. Fiber optics is one of the few technologies that can legitimately be referred to as “future-proof,” meaning that they will be able to provide customers with larger, better and faster service offerings as demand grows.

Fiber is able to provide better signals over longer distances. This does not hold true for copper cables since copper is susceptible to cross talk, more rapid signal attenuation, and interference that degrade the signal quality. Longer cables result in greater losses at any bandwidth or frequency of operation. To compensate for this, electrical signals need to be amplified or regenerated every few thousand feet using repeaters and amplifiers, whereas fiber optic signals can travel hundreds of miles without regeneration. This reduces the complexity and expense of operation and maintenance of networks comprised of fiber.

Optical fibers do not conduct electricity and are immune to other electromagnetic interferences. These properties allow optical fibers to be deployed where conductive materials would be hazardous, such as near power lines or within electric substations. Moreover, the cables do not corrode in the way that metallic components can over time, due to weather and environmental conditions, further reducing maintenance costs.

Copper cables transfer data in the form of electrical signals. This makes the data less secure, since it is more readily possible to physically “tap” in to the cables, especially twisted pair, and observe the data. Optical fibers are much more difficult to tap without breaking the connection, making the data they carry more secure.

### *2.3.2 FIBER HOLDS ADVANTAGE OVER WIRELESS TECHNOLOGIES*

Fiber and wireless are frequently posited as competing technologies, a common—but inaccurate—perception. Neither can supplant nor compete with the other; rather, ***these technologies inherently enhance and complement each other***. Wireless delivers mobility and fiber delivers capacity and speed. In addition, wireless needs fiber: for purposes of reliability and speed, a wireless network requires a robust fiber optic core backbone that connects it to core resources, to the Internet, and to other public networks. High wireless performance depends on backhaul over a core fiber network and, correspondingly, a wireless network will deliver poor performance if backhaul is inadequate, regardless of the quality of the wireless network itself.

Each network technology has its own distinct advantages and challenges, but fiber is a more flexible, future-proof, and capable technology—and a far less risky investment.

Wireless networks provide mobility and flexibility. Wireless holds a benefit with respect to speed to deployment and flexibility. However, there are significant challenges in providing effective wireless service. Design limitations such as power levels, spectrum availability, and required data capacity require that individual antennas or base stations serve limited areas, such as one mile or less. The challenge of deploying and managing wireless is also complicated if unlicensed frequencies are used for such technologies as WiFi. Further,

when a wireless provider needs to migrate to a more advanced technology platform, it may need to re-engineer and redesign its entire system.

Fiber networks hold the advantage in capacity, robustness, and security. Fiber provides almost unlimited capacity. Each single fiber optic strand is theoretically able to duplicate the entire electromagnetic spectrum available to all wireless users. In a practical sense, the capacity limit is imposed by the capability of the electronics connected to the fiber. Further, capacity is constantly increasing as technology improves. Fiber has a life of decades, assuming adequate maintenance, and it can cost-effectively and simply be scaled to dramatically higher speeds as new electronics become available.

There are significant challenges in fiber optic network technology, especially in the high cost of initial construction—particularly for underground installation or where extensive make-ready is required for aerial installation.

### 3. CURRENT BROADBAND OFFERINGS IN LAWRENCE

This section provides an overview discussion of the types and quality of broadband available in Lawrence, to the residential, business, and anchor institution markets. We begin with an overview of National Broadband Map (NBM) data pertaining to the City, and include a brief analysis of the City's existing broadband providers and networks.

The National Broadband Map (NBM; <http://www.broadbandmap.gov>) is the federal government's primary source of statistics regarding broadband availability nationwide.<sup>27</sup>

The NBM represents the first time that the United States has attempted to collect these data in one central location in order, ideally, to provide a picture of true broadband availability. It is important, however, to note that the map data are not sufficiently granular to give an accurate picture down to the address level (which would be an extremely difficult and costly task), for a number of reasons:

- First, the national map tracks availability only down to the Census block level; if any location in that block can be served, the entire block will be shown as served—even *if many or most of the residents do not actually have access*.
- The national map relies heavily on self-reporting by the commercial carriers—all of whom use different methodologies to quantify their service levels (and some of whom do not participate at all).
- The map fails to distinguish between residential broadband and connectivity that is adequate for institutions, government, and businesses; small businesses often need higher capacity broadband than residential users. And, even if broadband is shown on the NBM as available to the residential market, it may not be available to the small business market (and vice versa).
- The claimed wireless coverage generally does not take into account reduced signal levels indoors or in areas where terrain or other features obstruct the signal and reduce the speed and availability of service.

All of that said, the NBM is the logical first step in identifying the City's supply of broadband and is extremely helpful as a resource at less granularity than the address level.

---

<sup>27</sup> The NBM is a collaborative effort among the Federal Communications Commission and the Department of Commerce's National Telecommunications and Information Administration (NTIA). NTIA is also the agency that oversees the \$7.2 billion in Broadband Technology Opportunities Program (BTOP) stimulus grants authorized under the American Recovery and Reinvestment Act of 2009.

According to data from the map, 100 percent of Lawrence residents and businesses have access to some level of broadband service. The most ubiquitous broadband technology available in the City is wireless, followed closely by cable modem and DSL. Fiber optic infrastructure is generally not available to residential customers (Knology reportedly offers fiber service to a very small number of City premises and Wicked Broadband also has some fiber-to-the-home holdings, though it's not clear how extensive that footprint is).

Given that the NBM data rely heavily on self-reporting by the commercial carriers, the NBM may overstate the broadband coverage in the City. However, if the NBM's data are accurate or close to accurate, this broadband landscape suggests a monopolistic incumbent market.

Figure 3 below shows the NBM availability data for each technology type throughout the City.

**Figure 3: National Broadband Map Data—Lawrence Availability vs. Nationwide**

<b>Technology</b>	<b>Percent Population</b>	<b>Nationwide</b>
DSL	96.5%	89.5%
Fiber	0.5%	20.5%
Cable	100.0%	87.6%
Wireless	100.0%	99.0%
Other	0.0%	0.0%

The NBM indicates that the following providers offer service in Lawrence:

**Table 2: National Broadband Map Data—Broadband Providers in Lawrence**

<b>Provider</b>	<b>Technology</b>
AT&T	DSL, U-verse, Mobile Wireless
Kansas Broadband Internet, Inc.	Fixed Wireless
Knology, Inc.	Cable Modem (DOCSIS 3.0), Fiber-to-the-home, Fixed Wireless

Provider	Technology
Lawrence FreeNet (Wicked Broadband)	Fixed Wireless
Mercury Wireless, LLC	Fixed Wireless
Sprint Nextel Corporation	Mobile Wireless
T-Mobile	Mobile Wireless
Verizon Communications Inc.	Mobile Wireless

The NBM further reports that 100 percent of the population has access to download/upload speeds greater than 3 Mbps/0.768 Mbps.

**Figure 4: National Broadband Map Data—Broadband Speeds Available to City Residents**









Speed	Percent Population	Nationwide
Unreported	0.0%	0.0%
Download > 0.768 Mbps, Upload > 0.2 Mbps	100.0%	99.6%
Download > 3 Mbps, Upload > 0.768 Mbps	100.0%	98.2%

Source API Call

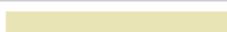
Broadband connectivity data for community anchor institutions (CAI) gathered at the state and national level are mostly incomplete. The NBM shows connectivity data for a total of only four sites (three schools and one library) out of 47 recognized CAI; this leaves about 91 percent of CAI records as unknown. (Data on CAIs connected to the City network are not included: NBM data are entirely carrier-reported.)

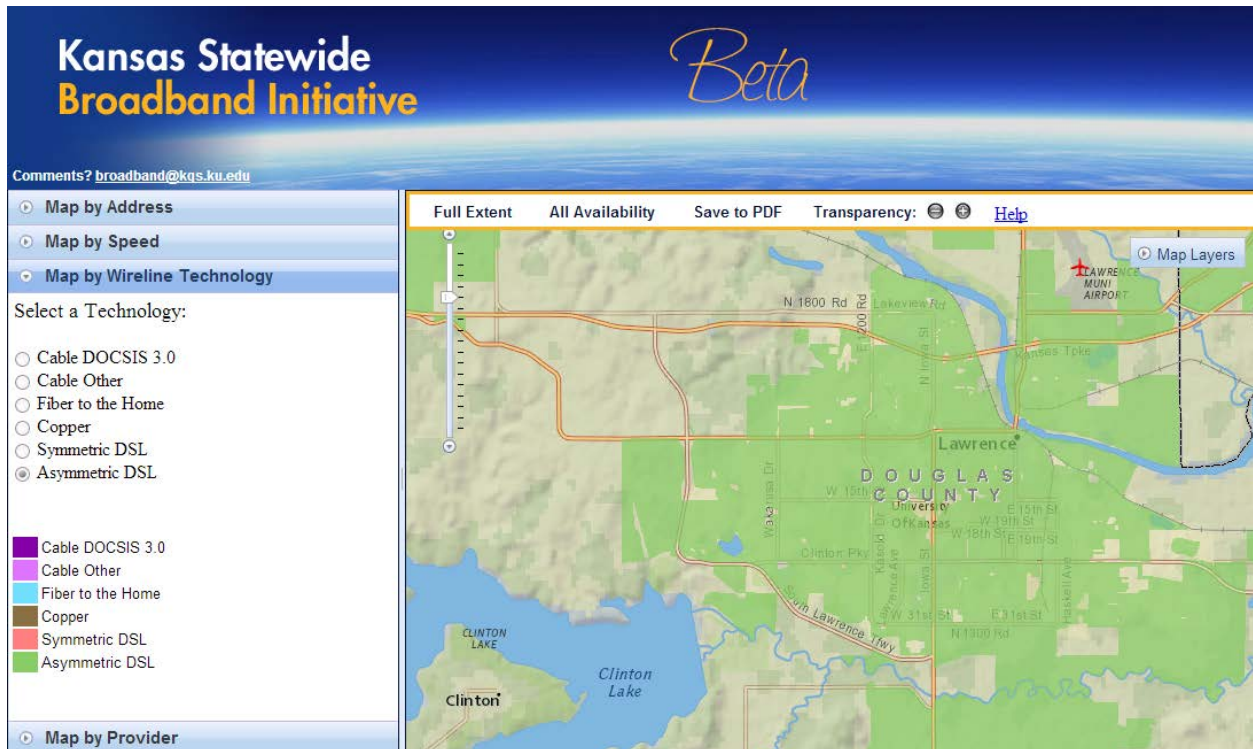

Figure 6: National Broadband Map—Number of Providers Available<sup>28</sup>

Number of Wireline Providers	Percent Population		Nationwide
0	0.0%		3.5%
1	3.6%		9.6%
2	96.5%		31.2%
3	0.0%		38.1%
4	0.0%		13.2%
5	0.0%		3.0%
6	0.0%		0.9%
7	0.0%		0.3%
8+	0.0%		0.2%

The Kansas Broadband Map confirms these claims. Both asymmetric DSL and cable modem service show very little gaps in service (see figures below).

Figure 7: Kansas Broadband Map—Asymmetric DSL Coverage in Lawrence<sup>29</sup>



<sup>28</sup> <http://www.broadbandmap.gov/summarize/state/kansas/census-places/lawrence>

<sup>29</sup> <http://broadband.kansasgis.org/map/>



Figure 8: Kansas Broadband Map—Cable DOCSIS 3.0 Coverage in Lawrence<sup>30</sup>

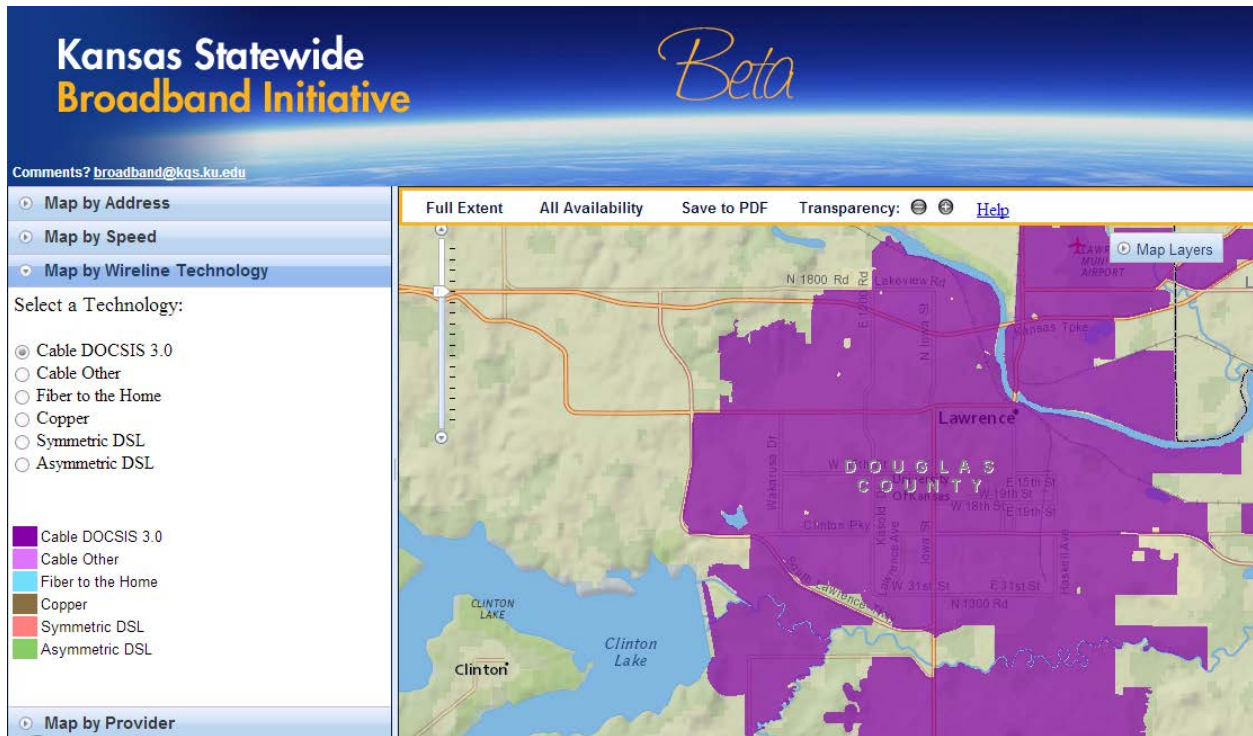

Despite universally available wireline and wireless broadband, however, the City's broadband landscape shows some notable differences from comparable communities. AT&T's U-verse appears to be available in the City only on a limited basis. While pricing for AT&T's DSL service is comparable to U-verse service when comparing similar speeds, higher-speed options available in some communities may not be offered in Lawrence. In addition, while Knology provides universal cable modem availability, this service comes with significant data limits. The table below summarizes the wireline service options available to Lawrence residents.

Table 3: Wireline Broadband Service Summary—Lawrence

Max. Download	Monthly Cost (Without Discounts)
<b>DSL and U-verse - AT&amp;T</b>	
768 Kbps	\$28.00
1.5 Mbps	\$36.00
3 Mbps	\$41.00
6 Mbps	\$46.00

<sup>30</sup> Ibid.

Max. Download	Monthly Cost (Without Discounts)
12 Mbps	\$51.00
<b>Cable – Knology<sup>31</sup></b>	
3 Mbps (5 GB Data Limit)	\$32.95
18 Mbps (50 GB Data Limit)	\$47.95
Variable Speed*, (No Data Limit) “Optimized for video” <sup>32</sup>	\$57.95

To put Lawrence’s broadband market in context, the tables below summarize corresponding services offered in the communities of Champaign-Urbana, Illinois, Madison, Wisconsin, and Ann Arbor, Michigan. Like Lawrence, these are cities with large state universities, concentrated urban centers, and highly educated populations.

**Table 4: Wireline Broadband Service Summary—Champaign-Urbana, IL**

Max. Download	Monthly Cost (Without Discounts)
<b>U-verse – AT&amp;T</b>	
768 Kbps/	\$28.00
1.5 Mbps	\$36.00
3 Mbps	\$41.00
6 Mbps	\$46.00
<b>Cable – Comcast<sup>33</sup></b>	
3 Mbps	\$29.95 to \$39.95
6 Mbps	\$49.95
20 Mbps	\$42.95 to \$62.95
50 Mbps	\$74.95
105 Mbps	\$114.95

<sup>31</sup> Modem rental is \$5 per month; \$10 per month discount when bundled with TV. Additional charges for exceeding data limits.

<sup>32</sup> <https://secure.kansas.knology.com/order?59=1#s2>

<sup>33</sup> Modem rental is \$7 per month; various discounts are available when bundled with TV and voice service

Table 5: Wireline Broadband Service Summary—Madison, WI

Max. Download Speed	Monthly Cost (Without Discounts)
<b><u>U-verse – AT&amp;T</u></b>	
3 Mbps	\$41.00
6 Mbps	\$46.00
12 Mbps	\$51.00
18 Mbps	\$56.00
24 Mbps	\$66.00
<b><u>Cable – Charter Communications</u></b>	
30 Mbps	\$29.99

Table 6: Wireline Broadband Service Summary—Ann Arbor, MI<sup>34</sup>

Max. Download Speed	Monthly Cost (Without Discounts)
<b><u>U-verse – AT&amp;T</u></b>	
3 Mbps	\$41.00
6 Mbps	\$46.00
12 Mbps	\$51.00
18 Mbps	\$56.00
24 Mbps	\$66.00
<b><u>Cable – Comcast<sup>35</sup></u></b>	
3 Mbps	\$29.95 to \$39.95
6 Mbps	\$49.95
20 Mbps	\$42.95 to \$62.95
50 Mbps	\$74.95

A number of notable limitations for Lawrence broadband customers are apparent from this picture. First, AT&T’s service is limited to DSL in some areas. Though AT&T does own fiber optic facilities in Lawrence, including the connection to City Hall, the fiber does not appear to be used for any FTTP services. The U-verse availability we found in Lawrence indicated maximum download speeds up to 12 Mbps, but the availability varies by specific location.

<sup>34</sup> Information for tables is from the following sources: <http://wwwb.comcast.com/>; <http://kansas.knology.com/internet/>; <http://www.att.com/shop/internet.html>; <http://www.charter.com/top/internet>

<sup>35</sup> Modem rental is \$7 per month; various discounts are available when bundled with TV and voice service

AT&T DSL subscribers can purchase services with a maximum download speed of 6 Mbps, which is limited even for DSL.

Second, on the cable modem side, Knology's pricing plan is built based on customers estimating their monthly bandwidth use in advance. Knology's prices are not wildly different from those of Comcast in Ann Arbor or Champaign-Urbana for the same download speeds. However, Comcast does not impose monthly data limits. Knology's 3 Mbps and 18 Mbps plans impose 5 gigabyte (GB) and 18 GB limits on bandwidth before charging additional fees, typically \$1 per extra GB. (To pay a lower overage rate, customers can request extra bandwidth be added to their plan in advance. This puts the burden on customers to predict and ration their monthly usage.)

Additionally, in Madison, Charter Communications offers cable modem service with download speeds of up to 30 Mbps for \$29.99 per month and no additional fee for modem rental. In terms of price and speed, this is the most competitive service plan of any listed here, and further emphasizes the limitations of Lawrence's cable service relative to other communities.

Finally, as an alternative to the wireline options in Lawrence, one fixed wireless provider, Wicked Broadband, offers advertised download speeds of up to 10 Mbps. (Knology, Mercury Wireless and Kansas Broadband Internet, Inc. also offer fixed wireless in parts of the City. Knology's wireless service primarily targets the rural areas outside of Lawrence, but the coverage includes some parts of the City.<sup>36</sup>) Wicked Broadband, which began as Lawrence FreeNet, offers WiFi connectivity, with a basic service plan costing \$38 per month.<sup>37</sup> Wicked Broadband serves a number of university fraternities and sororities, as well as residents throughout the City. Wireless broadband complements wireline service, but is not comparable. Wicked does not require yearly contracts, so it is an attractive option for non-permanent residents, but it also does not have additional bundled service options, and speeds over wireless networks can stall significantly during peak usage.

To conclude, we acknowledge the significance of universal broadband availability, and note that the private market does appear to offer wireline broadband access throughout the entire City. On the whole, however, the service offerings are costlier, slower, and more limited than in other comparable communities.

---

<sup>36</sup> [http://kansas.knology.com/sbb/internet/wrw\\_service.png](http://kansas.knology.com/sbb/internet/wrw_service.png)

<sup>37</sup> <http://www.lawrencefreenet.org/rates.php>

## 4. THE CASE FOR FOCUSING ON FIBER IN LAWRENCE

### 4.1 FIBER REPRESENTS THE PREFERRED MEDIUM FOR THE BROADBAND FUTURE

Fiber represents an infrastructure asset with a lifetime of decades that is almost endlessly upgradeable and capable of supporting any number of public or private sector communications initiatives.<sup>38</sup>

The key advantage fiber holds over other technologies is that it is future-proof. It enables not just today's high-bandwidth applications, but all applications in the foreseeable future, and can deliver a range of well-documented benefits to residents and businesses.

Indeed, the U.S. Ignite Partnership grew out of a White House Office of Science and Technology Policy roundtable discussion in January 2011 on how to develop applications that would maximize the benefit of fiber connectivity across the country. The public and private participants in U.S. Ignite are now working "to catalyze approximately 60 advanced, next-gen applications over the next five years in six areas of national priority: education and workforce development, advanced manufacturing, health, transportation, public safety, and clean energy."<sup>39</sup> (One fascinating fact about U.S. Ignite is that it seeks to enable private, commercial development of new, high-bandwidth applications, but most of the network infrastructure it makes available for that development is public—municipal fiber networks that connect many thousands of homes and provide a test-bed for advance application creation.)

Ubiquitous fiber also positions a community for a "converged" future, when a single broadband pipe—capable of delivering not just data, but telephone and video applications, as well—replaces the "triple play" bundle and relieves consumers of the need to purchase

---

<sup>38</sup> All broadband is not created equal, however. Fiber-to-the-premises (FTTP) is currently the most flexible and future-proof architecture of broadband—a fat pipe all the way into the home or business—but in the near future, it will only be available for a privileged few located in the limited areas of private-sector or municipal deployment. (Our competitor cities in Europe and Asia are increasingly adopting FTTP as the inevitable, essential broadband medium.)

<sup>39</sup> "What is U.S. Ignite?," U.S. Ignite website. <http://us-ignite.org/what-is-us-ignite/>.

multiple services.<sup>40</sup> Among current communications technologies (including wireless, cable, and copper), only fiber has that capacity.<sup>41</sup>

And fiber can enable applications that are inconceivable over other communications platforms, as illustrated by Figure 9 below and, in more detail, by Table 7 on the following page.

Figure 9: Fiber Capacity Compared to Other Broadband Technologies

### Time Required for Downloading and Uploading a 5 GB Network Backup File

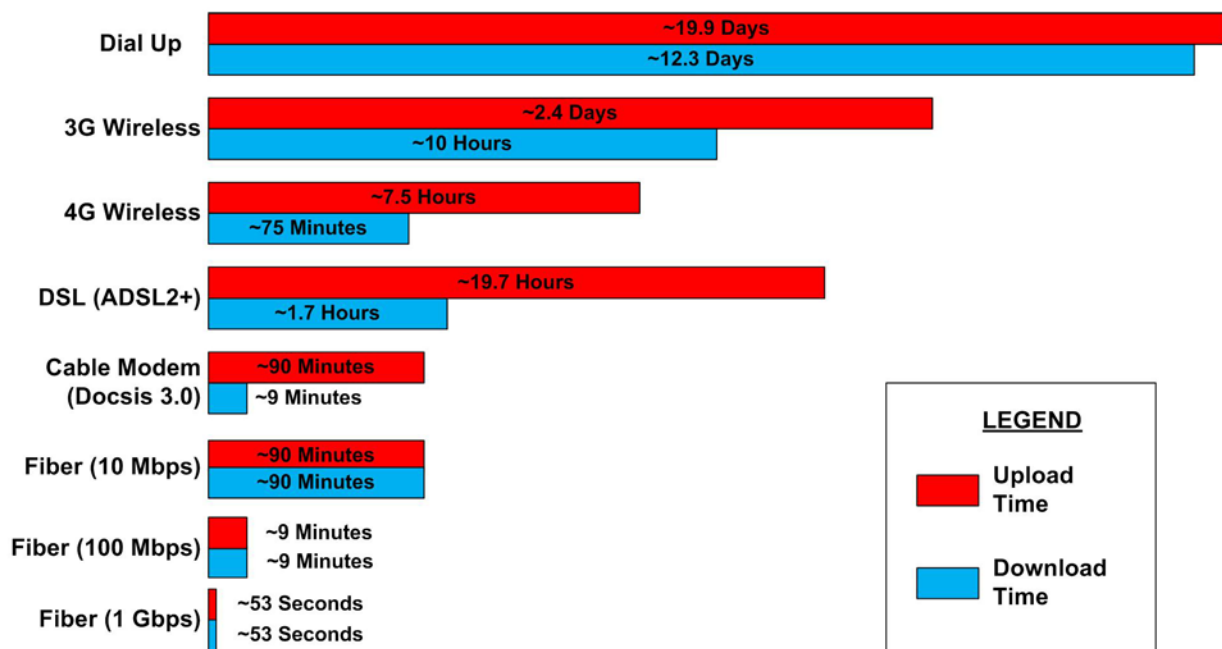

<sup>40</sup> The evolution of the cable television and landline telephone industries indicates that such a shift is already beginning; in Europe, HBO recently announced the availability of its programming over an Internet connection rather than a cable subscription. See: Stelter, Brian, "HBO Will Offer Channel by Internet in Northern Europe," *New York Times*, Sept. 2, 2012.

[http://mediadecoder.blogs.nytimes.com/2012/09/02/hbo-will-offer-channel-by-internet-in-northern-europe/?nl=technology&emc=edit\\_tu\\_20120904](http://mediadecoder.blogs.nytimes.com/2012/09/02/hbo-will-offer-channel-by-internet-in-northern-europe/?nl=technology&emc=edit_tu_20120904).

<sup>41</sup> The capacity needed for future applications (and many current applications, for that matter) should not be underestimated. Anyone tempted by the lower cost of less-capable infrastructure technologies would be wise to consider previous communications pioneers. America Online, for instance, did not imagine supporting Skype computer-to-computer calling when it rolled out dial-up Internet access across the country. Neither, for that matter, did the engineers at Apple imagine that their iPhone and similar devices would result in the creation of 500,000 applications (and counting). Consumers' already great demand for broadband capacity will only grow in the future, as the range of bandwidth-intensive applications (e.g., streaming video, data backup, telemedicine) grows.

**Table 7: Typical Applications and Their Performance over Various Download/Upload Broadband Speeds (Single User)**

<b>Applications</b>	<b>56 Kbps/ 56 Kbps</b> <i>(Dial-up, maximum speed)</i>	<b>256 Kbps/ 256 Kbps</b> <i>(DSL)</i>	<b>768 Kbps/ 384 Kbps</b> <i>(DSL; Satellite; 3G Wireless)</i>	<b>1 Mbps/ 384 Kbps</b> <i>(DSL; Satellite 3G/4G Wireless)</i>	<b>3 Mbps/ 768 Kbps</b> <i>(DSL; Satellite; 4G LTE Wireless)</i>	<b>7 Mbps / 768 Kbps</b> <i>(DSL; Cable; 4G LTE Wireless)</i>	<b>10 Mbps/ 1 Mbps</b> <i>(DSL; Cable; Fiber; 4G LTE Wireless)</i>	<b>15 Mbps/ 2 Mbps</b> <i>(DSL; Cable; Fiber)</i>	<b>20 Mbps/ 2 Mbps</b> <i>(Cable; Fiber)</i>	<b>50 Mbps/ 10 Mbps</b> <i>(Cable; Fiber)</i>	<b>100 Mbps/ 10 Mbps</b> <i>(Fiber)</i>	<b>1 Gbps/ 100 Mbps</b> <i>(Fiber)</i>
Simple text e-mail without attachments (50 KB)	OK (8 sec.)	Good (2 sec.)	Good (1 sec.)	Good (1 sec.)	Good (1 sec.)	Good (1 sec.)	Good (1 sec.)	Good (1 sec.)	Good (1 sec.)	Good (1 sec.)	Good (1 sec.)	Good (1 sec.)
Receive e-mail with medium attachments or graphics (500 KB)	Bad (72 sec.)	OK (16 sec.)	Good (6 sec.)	Good (4 sec.)	Good (2 sec.)	Good (1 sec.)	Good (1 sec.)	Good (1 sec.)	Good (1 sec.)	Good (1 sec.)	Good (1 sec.)	Good (1 sec.)
Download small files (e.g., a 50-page text document with limited graphics) (1 MB)	Bad (3 min.)	OK (32 sec.)	OK (11 sec.)	Good (8 sec.)	Good (3 sec.)	Good (2 sec.)	Good (1 sec.)	Good (1 sec.)	Good (1 sec.)	Good (1 sec.)	Good (1 sec.)	Good (1 sec.)
Download large files (e.g., new software or a large program update) (500 MB)	Bad (20 hr.)	Bad (5 hr.)	Bad (87 min.)	Bad (67 min.)	OK (23 min.)	OK (10 min.)	Good (7 min.)	Good (5 min.)	Good (4 sec.)	Good (80 sec.)	Good (40 sec.)	Good (1 sec.)
Download high-definition (HD) video (5 GB)	Bad (9 days)	Bad (44 hr.)	Bad (15 hr.)	Bad (12 hr.)	Bad (4 hr.)	Bad (96 min.)	Bad (67 min.)	Bad (45 min.)	OK (34 min.)	Good (14 min.)	Good (7 min.)	Good (40 sec.)
Upload videos, presentations (1 GB)	Bad (40 hr.)	Bad (9 hr.)	Bad (6 hr.)	Bad (6 hr.)	Bad (3 hr.)	Bad (3 hr.)	Bad (134 min.)	OK (67 min.)	OK (67 min.)	Good (14 min.)	Good (14 min.)	Good (80 sec.)
Daily incremental backup, up to 20 GB	Bad (> 1 day)	Bad (> 1 day)	Bad (> 1 day)	Bad (> 1 day)	Bad (> 1 day)	Bad (> 1 day)	Bad (> 1 day)	Bad (23 hr.)	Bad (23 hr.)	OK (5 hr.)	OK (5 hr.)	Good (27 min.)

Enhancing Broadband in Lawrence

April 2013

Page 34

<b>Applications</b>	<b>56 Kbps/ 56 Kbps</b> <i>(Dial-up, maximum speed)</i>	<b>256 Kbps/ 256 Kbps</b> <i>(DSL)</i>	<b>768 Kbps/ 384 Kbps</b> <i>(DSL; Satellite; 3G Wireless)</i>	<b>1 Mbps/ 384 Kbps</b> <i>(DSL; Satellite 3G/4G Wireless)</i>	<b>3 Mbps/ 768 Kbps</b> <i>(DSL; Satellite; 4G LTE Wireless)</i>	<b>7 Mbps / 768 Kbps</b> <i>(DSL; Cable; 4G LTE Wireless)</i>	<b>10 Mbps/ 1 Mbps</b> <i>(DSL; Cable; Fiber; 4G LTE Wireless)</i>	<b>15 Mbps/ 2 Mbps</b> <i>(DSL; Cable; Fiber)</i>	<b>20 Mbps/ 2 Mbps</b> <i>(Cable; Fiber)</i>	<b>50 Mbps/ 10 Mbps</b> <i>(Cable; Fiber)</i>	<b>100 Mbps/ 10 Mbps</b> <i>(Fiber)</i>	<b>1 Gbps/ 100 Mbps</b> <i>(Fiber)</i>
Telemedicine (e.g., radiological images such as mammograms) (160 MB download)	Bad (7 hr.)	Bad (84 min.)	Bad (28 min.)	Bad (22 min.)	Bad (8 min.)	Bad (4 min.)	Bad (3 min.)	Bad (86 sec.)	Bad (64 sec.)	Good (26 sec.)	Good (13 sec.)	Good (2 sec.)
Web browsing	Bad	Bad	OK	OK	Good	Good	Good	Good	Good	Good	Good	Good
Interactive online applications (trading, e-business, online meeting presentation and document sharing, gaming)	Bad	Bad	Bad	OK	OK	Good	Good	Good	Good	Good	Good	Good
Videoconferencing streaming at 384 Kbps (desktop/single user)	Bad	Bad	Bad	Bad	OK	OK	OK	Good	Good	Good	Good	Good
Telecommuting/server access (VPN client)	Bad	Bad	Bad	Bad	Bad	Bad	OK	OK	OK	Good	Good	Good
Multi-point videoconferencing streaming at 768 Kbps for a group of 5 to 6	Bad	Bad	Bad	Bad	Bad	Bad	Bad	Bad	Bad	Good	Good	Good
Stream HD video (3 – 5 Mbps)	Bad	Bad	Bad	Bad	Bad	OK	OK	Good	Good	Good	Good	Good
Distance learning	Bad	Bad	Bad	Bad	Bad	Bad	Bad	OK	OK	Good	Good	Good



The table defines performance needs from today's perspective.<sup>42</sup> The demand for higher-capacity connections will continue to rise—as, for example, more small businesses explore public or private “cloud computing” services, which support and deliver hosted applications and storage over the Internet.

## 4.2 THE ECONOMIC DEVELOPMENT IMPACT OF HIGH-CAPACITY BROADBAND IS GROWING

The implementation of fiber-to-the-premises (FTTP) by Verizon and others has been a significant step in raising the bar for experiencing the potential of high-speed communications. However, those deployments are now being contrasted to a new generation of FTTP networks that offer gigabit-per-second (Gbps) capacity to end-users. As these broadband technologies continue to develop, and as their implementation focuses in select population centers, there exists the opportunity to see the differences in economic impacts across the country and elsewhere.

There is certainly a perception among many communities that gigabit speeds offer new opportunities for economic development:

- The State of Illinois has launched an “Illinois Gigabit Communities Challenge,” a contest that will award the winner funding to build or expand ultra-fast networks, with a clear emphasis on economic development incentives.<sup>43</sup>
- The same rhetoric is now being used on the national level, with outgoing FCC Chairman Julius Genachowski issuing the “Gigabit City Challenge” this past January. This challenge calls for at least one gigabit community in all 50 states.<sup>44</sup>

---

<sup>42</sup> The table assumes:

- A single user.
- For downloading small files up to 1 MB, download time less than 10 seconds is good, 10 to 15 seconds is fair, and more than 15 seconds is not acceptable.
- For uploading videos of 1 GB, upload time less than 30 minutes is good, 30 to 90 minutes is fair, and more than 90 minutes is not acceptable.
- For downloading high-definition videos (2 GB), download time less than 10 minutes is good, 10 to 15 minutes is fair, and more than 15 minutes is not acceptable.
- For applications such as videoconferencing and remote server access, no concurrent usage of the same application by the same user.
- Server back-up will normally occur during off-peak times (10 p.m. to 6 a.m.).
- For telemedicine files up to 160 MB, download time of less than 30 seconds is good, 30 to 60 seconds is fair, and more than 60 seconds is unacceptable.

<sup>43</sup> Illinois Gigabit Communities Challenge, (<http://www2.illinois.gov/gov/gigabit/Pages/default.aspx>).

<sup>44</sup> NEWS, Federal Communications Commission, January 18, 2013, ([http://transition.fcc.gov/Daily\\_Releases/Daily\\_Business/2013/db0118/DOC-318489A1.pdf](http://transition.fcc.gov/Daily_Releases/Daily_Business/2013/db0118/DOC-318489A1.pdf)).

- The City of Chattanooga, Tennessee's community-owned network touts its gigabit speeds as a boon to new businesses.
- Kansas City boasts of being a new "silicon prairie" due to the draw of Google Fiber.
- Other communities are pursuing their own municipal gigabit networks, including Lafayette, Louisiana and Gainesville, Florida.

If gigabit FTTP networks make a difference when it comes to economic development, it is through the new applications they enable. To the extent these applications make a significant impact on economic activity in a community, then the potential exists for gigabit speeds to be an economic catalyst in a new way. Google, in particular, has made a significant investment in demonstrating that gigabit fiber will enable new, transformative uses and applications of broadband.

Indeed, the U.S. Ignite Partnership grew out of a White House Office of Science and Technology Policy roundtable discussion in January 2011 on how to develop applications that would maximize the benefit of fiber connectivity across the country. The public and private participants in U.S. Ignite are now working "to catalyze approximately 60 advanced, next-gen applications over the next five years in six areas of national priority: education and workforce development, advanced manufacturing, health, transportation, public safety, and clean energy."<sup>45</sup>

Establishing a causal relationship between the availability of ultra-fast broadband and economic development can be difficult because we are analyzing a type of broadband deployment in its infancy.

Despite these difficulties, the literature available on broadband and economic development does suggest a causal relationship between broadband and economic development. High-speed broadband is an economic enabler for businesses. From the standpoint of most businesses, broadband has ceased to be a luxury and has become crucial to business functionality.

According to a 2011 survey of building owners and property managers, broadband access is one of the most important decision factors for commercial real estate siting—after price, parking, and location. Similarly, a national survey found that 77 percent of economic development professionals believe that to attract a new business, a community must have

---

<sup>45</sup> "What is U.S. Ignite?," U.S. Ignite website. <http://us-ignite.org/what-is-us-ignite/>. One fascinating fact about U.S. Ignite is that it seeks to enable private, commercial development of new, high-bandwidth applications, but most of the network infrastructure it makes available for that development is public—municipal fiber networks that connect many thousands of homes and provide a test-bed for advance application creation.

broadband of at least 100 Mbps; in other words, they believe that economic development without broadband is essentially inconceivable.

The high speeds that fiber provides can facilitate economic development by:

1. Enabling small business creation and growth
2. Enabling job creation and the enhanced, multiplied economic activity that accompanies it
3. Supporting businesses with very high bandwidth needs, such as digital media and software development
4. Attracting and retaining businesses of all sizes
5. Enabling workforce education
6. Enabling telework and distributed work
7. Stimulating economic activity
8. Enhancing the City's reputation for visionary and pioneering projects
9. Promoting major development initiatives such as revitalization zones

A number of studies show a significant positive effect on economic growth by the increase of broadband speeds.<sup>46</sup> Whether these economic impacts are significantly enhanced by gigabit FTTP availability is a related but separate question. Importantly, evidence from research further supports the conclusion that connection speed is the most important factor in broadband adoption.<sup>47</sup>

That said, people who live or work in the few places where these networks exist or are being built (such as Kansas City and Chattanooga) can experience some of the fastest connection speeds available today—and their experiences can illustrate the economic benefit of their networks.

---

<sup>46</sup> Press Release: "New study quantifies the impact of broadband speed on GDP," Ericsson, September 27, 2011. (<http://www.ericsson.com/news/1550083>).

Sharon E. Gillett, Dr. William H. Lehr, et al., "Measuring the Economic Impact of Broadband Deployment," Final Report Prepared for the U.S. Department of Commerce, Economic Development Administration, National Technical Assistance, Training, Research, and Evaluation Project #99-07-13829, February, 2006, ([http://cfp.mit.edu/publications/CFP\\_Papers/Measuring\\_bb\\_econ\\_impact-final.pdf](http://cfp.mit.edu/publications/CFP_Papers/Measuring_bb_econ_impact-final.pdf)).

Jed Kolko and Davin Reed, "Does Broadband Boost Local Economic Development," Public Policy Institute of California, January 2010, p. 28. ([http://www.ppic.org/content/pubs/report/r\\_110jkr.PDF](http://www.ppic.org/content/pubs/report/r_110jkr.PDF)).

<sup>47</sup> "Benefits of Broadband," *Broadband Communities*, November/December 2012, p. 54.

#### 4.2.1 KANSAS CITY

Despite industry warnings about lack of demand, a recent survey showed 60 percent<sup>48</sup> of those qualifying for Google Fiber were very interested in adopting the service.<sup>49</sup> Though the network is not yet fully activated, signs of increased economic activity in Kansas City have in fact emerged.

According to the *Washington Post*, “about a dozen start-ups have launched in the first neighborhood to get Google’s 1-gigabit-per-second service” as of January.<sup>50</sup> Early evidence suggests that much of the significant use of the gigabit speeds are by technology companies. For example, the company EyeVerify, a security software developer, relocated its office to one of Google’s “fiberhoods”—designated neighborhoods that attained Google’s quota of interested customers; the company founder has stated that Google Fiber is allowing the business to operate far more efficiently. EyeVerify deals with very large data files—detailed scans of eyes for security identification—so it demonstrates how the gigabit network opens the door for better application use.<sup>51</sup> It is, of course, a very specialized market that uses such applications, suggesting that the economic development created by gigabit capacity may be heavily focused on the technology sector.

Indeed, Kansas City is gaining the reputation as a magnet for startup businesses in the tech industry, and just the draw of the new “prairie” has created some interesting economic incentivizing. Grassroots initiatives include the Kansas City Startup Village and the unconventional “Homes for Hackers,” a temporary housing option for tech developers looking to start a business in Kansas City. Homeowners can volunteer their Google Fiber-connected properties to these aspiring entrepreneurs, who can live rent-free for three months while they work on their projects with gigabit speeds.<sup>52</sup>

---

<sup>48</sup> A free 5 Mbps (down) / 1 Mbps (up) option is also available, so it cannot be assumed that all of these respondents would opt for gigabit service.

<sup>49</sup> Karl Bode, “Google Fiber Has No Problem With Customer Demand,” *Broadband DSL Reports*, January 11, 2013, (<http://www.broadbandreports.com/shownews/Google-Fiber-Has-No-Problem-With-Customer-Demand-122709>).

<sup>50</sup> Cecilia Kang, Google Fiber provides faster Internet and, cities hope, business growth,” *The Washington Post*, January 25, 2013, ([http://www.washingtonpost.com/business/technology/google-fiber-provides-faster-internet-and-cities-hope-business-growth/2013/01/25/08b466fc-6028-11e2-b05a-605528f6b712\\_story.html](http://www.washingtonpost.com/business/technology/google-fiber-provides-faster-internet-and-cities-hope-business-growth/2013/01/25/08b466fc-6028-11e2-b05a-605528f6b712_story.html)).

<sup>51</sup> Id.

<sup>52</sup> Maria Sudekum, “Google’s Ultrafast Internet Draws Startups to KC,” *Associated Press*, January 13, 2013, (<http://bigstory.ap.org/article/googles-ultrafast-internet-draws-startups-kc>).

It is easy to see that Google Fiber has become a point of pride in the local culture, which is important when competing with places more commonly thought of as magnets for startups, such as Palo Alto.<sup>53</sup>

#### 4.2.2 CHATTANOOGA

On the public networking side, Chattanooga has had an operational gigabit network since 2010. The network model, provided by the community-owned Electric Power Board (EPB), is heavily application driven. The City itself has adopted the use of many new applications, including a 16 megabit-per-second (Mbps) WiFi service for government use, which uses the gigabit network as backhaul; uploading and sharing 3D scans of buildings and facilities among City public works personnel; and criminal investigations utilizing remote collaboration by the City police force.<sup>54</sup>

In the private sector, Chattanooga has, like Kansas City, shown encouraging signs of becoming a tech incubator; the gigabit hookup allows businesses that perform high-end simulations, like Chattanooga's SimCenter Enterprises, to work among major corporate and research collaborators worldwide. The network "enables a small company in a mid-sized city to become the center of a world of supercomputers, international research teams and corporate giants."<sup>55</sup> Chattanooga is also openly vying to become a small computer gaming enclave, and gamers and game developers have taken notice.<sup>56</sup>

Beyond the tech industry, however, as in Kansas City, the results are less clear when it comes to adoption and returns. Officials at EPB have acknowledged that widespread demand for the service has not been immediately apparent.<sup>57</sup> Nevertheless, the network began turning a profit in 2011, and EPB seems confident in its business model, believing that the applications will come if the capacity is there.<sup>58</sup>

#### 4.2.3 INTERNATIONAL RESEARCH PAINTS A STRONG PICTURE

To get a sense of the economic impacts of ultra-fast networks over time, we need to look outside of the United States. Significantly, the debate about the economic impact of FTTP is

---

<sup>53</sup> Id.

<sup>54</sup> Craig Settles, "Why Chattanooga Represents Broadband's Future," GIGAOM, May 29, 2011, (<http://gigaom.com/2011/05/29/take-the-chattanooga-choo-choo-to-the-internets-future/>).

<sup>55</sup> Craig Settles, "What a Gigabit Network Can Do? Find Out," GIGAOM, May 30, 2011, (<http://gigaom.com/2011/05/30/chattanooga-shows-what-a-gigabit-network-can-do/>).

<sup>56</sup> Craig Settles, "Why Chattanooga Represents Broadband's Future," GIGAOM, May 29, 2011, (<http://gigaom.com/2011/05/29/take-the-chattanooga-choo-choo-to-the-internets-future/>).

<sup>57</sup> Nate Anderson, "How do you use 1Gbps Internet links? Chattanooga residents find out," *Ars Technica*, April 27, 2011, (<http://arstechnica.com/tech-policy/2011/04/how-chattanooga-uses-1gbps-internet-connections/>).

<sup>58</sup> Id.

largely a U.S. debate. The importance of FTTP to future economic development and competitiveness is taken as a given in much of Europe and the developed nations of Asia—most of which have made public investments in FTTP that, on average, are hundreds of times larger than the public broadband investments made by the United States through the 2009 Recovery Act broadband programs.<sup>59</sup>

In Singapore, for example, the government has set its sights on a gigabit as the *minimum* speed for the entire country. The iN2015 Masterplan seeks to make Singapore number one in the world “in harnessing infocomm to add value to the economy and society.”<sup>60</sup> They offer concrete goals, including the creation of 80,000 jobs and increases “in the value-add of the infocomm industry to \$26 billion” and “in infocomm export revenue to \$60 billion.”<sup>61</sup> An ultra-fast network that provides near universal service across the country is a non-controversial goal, and the anticipated economic impacts are taken as a given.

International research shows that the economic benefits of broadband are particularly high for FTTP investment. A study sponsored in part by the Swedish government shows that FTTP spending yields about a 50 percent return on investment (ROI).<sup>62</sup> Increased market competition and efficiency among local governments appeared to account for a significant portion of the savings, but there was also an observed positive effect on employment and population. The study concluded that if Sweden built out FTTP to the entire country at a cost of \$5.9 billion, the ROI would be \$8.6 billion.<sup>63</sup>

In 2011, a broader study conducted by Ericsson, Arthur D. Little, and Chalmers University of Technology among 33 countries quantified the impact of connection speed on GDP.<sup>64</sup> The findings of this study are highly significant to gigabit FTTP networks, because they show a significant positive impact on GDP as a function of broadband speed. Previously, some of the same researchers had found that GDP increases by 1 percent for each 10 percentage points of broadband penetration.<sup>65</sup> Raúl L. Katz of Columbia Business School

---

<sup>59</sup> Nationwide FTTP construction projects are near completion or underway in Australia, China, Malaysia, New Zealand, Singapore, South Korea, and other Asian nations. More localized investments have been made in significant parts of Western Europe. And the European Union and its members have undertaken significant regulatory change designed to spur FTTP investment by the private sector.

<sup>60</sup> iN2015 Masterplan, Infocomm Development Authority of Singapore, (<http://www.ida.gov.sg/Infocomm-Landscape/iN2015-Masterplan.aspx>).

<sup>61</sup> Id.

<sup>62</sup> “Benefits of Broadband,” *Broadband Communities*, November/December 2012 p. 56.

<sup>63</sup> Id.

<sup>64</sup> Study conducted jointly by Ericsson, Arthur D. Littler, and Chalmers University of Technology.

<sup>65</sup> Press Release: “New study quantifies the impact of broadband speed on GDP,” Ericsson, September 27, 2011. (<http://www.ericsson.com/news/1550083>).

presents concurring data, with a wide variation of growth among various countries, but a clear link between level of penetration and economic returns.<sup>66</sup>

The 2011 study predicts that GDP increases by 0.3 percent when broadband speed doubles; and the effect is repeatable. The report states: “The study also shows that additional doublings of speed can yield growth in excess of 0.3 percent (e.g. quadrupling of speed equals 0.6 percent GDP growth stimulus).”<sup>67</sup> So, if a country with average speeds of, for example, 10 Mbps—a generous hypothetical assumption for the United States—saw its average speed increase to 1 Gbps, this would be a hundred-fold increase in average speed, and predict at least a 2.1 percent increase in GDP (since the speed would have doubled more than seven times).

The study observes that growth takes two forms, the first being the short-term economic stimulus caused by the deployment, and the second being the creation of new businesses and increased productivity.<sup>68</sup> The latter type of economic boost is what can be sustained over the long-term. According to multiple sources, the cost-savings and production boosts that ultra-fast networks can bring depend on how readily businesses adopt service, and then adapt their practices to leverage the new capacity. In other words, it is only after businesses purchase the service and have it for long enough to change their organizational and strategic practices to make use of the new applications available to them that they will begin to see a true ROI.<sup>69</sup>

Doug Adams and Michael Currie of the Strategic Networks Group (SNG) make the claim that “developers of ultra-fast broadband networks too often remain focused on the innovation element of their networks rather than moving on to address communication, time and social systems.”<sup>70</sup> An earlier study, also by SNG, claims that “the most significant gains from FTTP occur after 2 years of use once organizations have adopted new business

---

<sup>66</sup> Dr. Raúl L. Katz, Presentation: “The Impact of Broadband on the Economy: Research to Date and Policy Issues,” 10th Global Symposium for Regulators, “Enabling Tomorrow’s Digital World”, November 10, 2010, (<http://www.itu.int/ITU-D/treg/Events/Seminars/GSR/GSR10/documents/GSR10-ppt1.pdf>).

<sup>67</sup> Press Release: “New study quantifies the impact of broadband speed on GDP,” Ericsson, September 27, 2011.

(<http://www.ericsson.com/news/1550083>).

<sup>68</sup> Id.

<sup>69</sup> Doug Adams and Michael Curri, “Broadband Is No Field of Dreams,” *Broadband Communities*, November/December 2012, p. 37.

<sup>70</sup> Id.

models to realize new revenue streams and to transform their business operations for cost avoidance.”<sup>71</sup>

Adams and Currie’s analysis stands in contrast to the “if you build it they will come” argument made by some gigabit promoters (as in Chattanooga, for example). They hold that ultra-fast broadband is not a utility but “a new technology that many see as a luxury, and it should be sold by touting the benefits...rather than the feature of speed.”<sup>72</sup>

In the end, these two views may not be so far apart. Experience seems to be showing that “if you build it they will come” does seem to hold true among tech start-ups and data-driven industries, but not necessarily among other business sectors, which need time and persuasion in order to adopt and adapt. It is also apparent that this distinction of behavior between tech companies and others is observable outside of the United States.<sup>73</sup> A chapter in a recent report on the Australian National Broadband Network goes so far as to describe the need for businesses to view new access to high-speed Internet as a “shock”—something potentially disruptive and initially negative, but ultimately beneficial once a business gets the right strategy in place.

But these studies all seem to agree that the gains are real. The current economic impacts of specifically ultra-fast networks are still emerging. Both adoption and speeds matter for these economic impacts, and speed is not the only benefit of FTTP technology; the reliability of fiber networks is also an important incentive for businesses to adopt service.<sup>74</sup> If a company is going to transform its entire business model based on its network capacity, all the bandwidth in the world would not matter without the certainty that the network will operate as expected every day. Nevertheless, there is clear consensus that a significant component of the economic development associated with broadband is speed-driven, especially since speed is such an important factor in encouraging adoption in the first place.

---

<sup>71</sup> “The Transformative Effects of FTTP,” Strategic Networks Group, (<http://www.ftthcommunitytoolkit.wikispaces.net/file/view/SNG+-+The+Transformative+Effects+of+FTTP+-+issued+Mar+2008.pdf>).

<sup>72</sup> Doug Adams and Michael Curri, “Broadband Is No Field of Dreams,” *Broadband Communities*, November/December 2012, p. 37

<sup>73</sup> Brian Ramsay, “Catalyzing Regional Business Development Through High Speed Broadband: Opportunities and Risks,” Chapter 14 in *Regional Advantage and Innovation: Achieving Australia’s National Outcomes*, Ed: Susan Kinnear, Kate Charters, Peter Vitartas, New York: 2013. <http://books.google.com/books?hl=en&lr=&id=68bsrtc5xrIC&oi=fnd&pg=PA269&dq=gigabit+broadband+economic+development&ots=ylljvV5Ack&sig=7IDatPqe1TcWh02pcGDCHqjL-Lc#v=onepage&q=gigabit%20broadband%20economic%20development&f=false>

<sup>74</sup> “The Transformative Effects of FTTP,” Strategic Networks Group, (<http://www.ftthcommunitytoolkit.wikispaces.net/file/view/SNG+-+The+Transformative+Effects+of+FTTP+-+issued+Mar+2008.pdf>).



### 4.3 FIBER OFFERS SIGNIFICANT BENEFITS TO PUBLIC SAFETY USERS

A government-owned fiber communications network does not rely on physical infrastructure, equipment, or other resources that carry public traffic for residents and businesses. The advantage of an independent network over leased circuits, then, is that it is not affected by increases in public traffic or public network outages; it is also less susceptible to the myriad threats to public computing networks (e.g., increased risk of hacking, DNS failures, DOS attacks, viruses, and worms).

During major public safety incidents, for example, public networks such as the Public Switched Telephone Network (PSTN), the Internet, and mobile cellular networks are often overloaded by the amount of traffic on the network. (The same outages and overloading can occur due to deliberate attempts by hackers to disrupt public networks.) This can lead to busy signals on the PSTN and a lack of connectivity on the Internet or over cellular phones. Privately owned networks typically do not experience the same traffic increases and can be designed to handle any expected traffic increase during a major incident.

The operators of many public networks (e.g., the Internet, cellular networks) are in the planning and early implementation stages of providing priority and preemption capabilities, so those capabilities are not yet universally available. In the event of a crisis, however, priority and preemption is critical for public safety networks.

In addition, a government-owned fiber optic network can prioritize bandwidth both in the core and at the edge. This capability would allow the City to prioritize by location and preempt all traffic other than public safety traffic, if necessary. More importantly, a City-owned infrastructure can be allocated so that sensitive traffic always has dedicated capacity, because capacity can be readily scaled as needed for other applications.

In contrast, managed network service providers routinely use shared resources to reduce their cost. Commercial carriers intentionally oversubscribe their networks to minimize costs (and maximize profits), because all of their customers are not likely to simultaneously use their services to full capacity all of the time.

### 4.4 HIGH-CAPACITY BROADBAND OVER FIBER IS CRUCIAL FOR COMMUNITY ANCHOR INSTITUTIONS

Nationally, the need for bandwidth by community anchor institutions (CAI) such as public safety facilities, schools, libraries, and hospitals is growing dramatically and is fundamental to state and local interests. The Federal Communications Commission's (FCC) National Broadband Plan establishes as one of the nation's key goals that "[e]very community

should have affordable access to at least 1 gigabit per second broadband service to anchor institutions such as schools, hospitals, and government buildings.”<sup>75</sup> Such speeds are increasingly needed to support the growing demand for high-speed Internet access in education, public libraries, and medicine.

The sections below demonstrate the many applications that local governments, schools, libraries, and hospitals use (and will use in the future) that require higher bandwidth.

#### *4.4.1 HIGH BANDWIDTH NEEDS FOR LOCAL GOVERNMENT*

Schools, libraries, and hospitals are major drivers of broadband demand; they are large institutions, serving thousands of students, providing communities with free Internet access, and providing high-tech health care to remote areas. What may be less obvious are the broadband uses of other aspects of local government, which are essential to providing a range of public services and governing effectively.

The Internet has become the first, and often the only, place people go to find information on government services. The National Association of Telecommunications Officers and Advisors (NATOA) has emphasized how local governments rely on broadband to “inform citizens, provide essential services, transact business, make government more transparent and promote civic engagement”—and that “citizen demand for online local government services and content has contributed to greater adoption of broadband.”<sup>76</sup>

Government websites are no longer simply online brochures; they are portals that allow citizen communication and participation. Residents can pay parking tickets, apply for permits, sign up to speak at public hearings, watch public programming, report potholes, and so on. The Internet is, in many communities, the most common way of contacting elected officials and agencies. And the interaction goes both ways: Cities, counties, and elected officials are using Facebook, Twitter, and other social media to engage directly with their citizens. Broadband reduces the barriers between governments and their communities.

Reliable high-speed networks are critical to the changing needs of law enforcement and public safety agencies, as well. There are numerous applications for local officials to use in this area. In addition to the many wireless applications that can help emergency personnel cut precious seconds off of their response times, robust wireline networks play a critical

---

<sup>75</sup> National Broadband Plan: Connecting America, Goal 4.

<http://www.broadband.gov/plan/goals-action-items.html>

<sup>76</sup> Comments of the National Association of Telecommunications Officers and Advisors (NATOA), National League of Cities (NLC), United States Conference of Mayors (USCM), and National Association of Counties (NACo), GN Docket Nos. 09-47, 09-51, 09-137

role in public safety, due to their speed, bandwidth, and reliability. Police officers can participate in criminal arraignments remotely, saving the government thousands in transportation costs and freeing officers to spend more time protecting communities. Traffic systems, including signals wired with fiber optics, can be monitored and adjusted in real-time in response to events. Highway accidents, weather events, and other emergencies can be broadcast to thousands of users simultaneously through public alert systems via e-mail or text message. The improvement to efficiency in public safety created by high-speed network service is hard to overstate.

During large-scale, regional emergencies, secure multi-party communications are often required, and wireless facilities may become overwhelmed and unusable. Many local jurisdictions nationwide have taken steps to address these needs. For example, the National Capital Region, comprising Washington, D.C. and the surrounding jurisdictions, has built a fiber optic interoperability network known as NCRnet. Built for “security, reliability, and high bandwidth,” NCRnet was created specifically to address the needs of first responders and emergency support personnel.<sup>77</sup> The high capacity and redundancy of the fiber network structure lends itself to reliable videoconferencing capacity, ensuring the ability for real-time coordination during a regional emergency.

The variety and scale of government applications demands the big bandwidth that fiber provides. As populations grow, institutional broadband needs will grow accordingly; and as data storage and applications move off of conventional hard drives and into the cloud, government institutions will become increasingly bandwidth hungry. These realities point to the need for future-proof institutional network infrastructure, which fiber provides.

#### 4.4.2 HIGH BANDWIDTH NEEDS IN EDUCATION

The U.S. Department of Commerce has found that schools require connections of 50 to 100 Mbps per 1,000 students.<sup>78</sup> Education technologists recommend even greater capacity; in an environment where students are bringing up to three devices each to school, some recommend that schools provide 300 to 600 Mbps *per classroom*, which delivers a few megabits per student to support video learning.<sup>79</sup>

---

<sup>77</sup> [http://www.broadband.gov/docs/ws\\_pshs/pshs\\_afflerbach\\_reference.pdf](http://www.broadband.gov/docs/ws_pshs/pshs_afflerbach_reference.pdf)

<sup>78</sup> Federal Communications Commission, Eighth Broadband Progress Report, In the Matter of Inquiry Concerning the Deployment of Advanced Telecommunications Capability to All Americans in a Reasonable and Timely Fashion, and Possible Steps to Accelerate Such Deployment Pursuant to Section 706 of the Telecommunications Act of 1996, as Amended by the Broadband Data Improvement Act, August 14, 2012, GN Docket No. 11-121, at 133.

<sup>79</sup> Tanya Roscorla, “5 Ways to Prepare Schools for Bring Your Own Device,” Center for Digital Education, December 10, 2012, <http://www.centerdigitaled.com/news/5-Ways-to-Prepare-Schools-for-Bring-Your-Own-Device.html>.

The State Educational Technology Directors Association (SETDA) recommends that by the 2014–15 school year, each school have at least 100 Mbps Internet per 1,000 students and staff (service to the public *Internet*) and at least 1 Gbps for each 1,000 students and staff connecting the schools to each other and to their district building (*intranet* service).

These recommendations increase in the 2017–18 school year to 1 Gbps for every 1,000 students and teachers for an external connections and 10 Gbps for internal network connections, “in anticipation of future technologies not yet conceived.”<sup>80</sup>

**Table 8: Recommended Bandwidth for Schools**

<b>Broadband Access for Teaching, Learning and School Operations</b>	<b>2014-2015</b>	<b>2017-2018</b>
An external Internet connection to the Internet Service Provider (ISP)	At least 100 Mbps per 100 students/ staff	At least 1 Gbps per 100 students/ staff
Internal wide area network (WAN) connections from the district to each school and among schools within the district	At least 1 Gbps per 1,000 students/ staff	At least 10 Gbps per 1,000 students/ staff

Source: State Educational Technology Directors Association

A significant number of the nation’s schools suffer from inadequate Internet access. Insufficient bandwidth precludes creative and expansive online learning, such as video conferencing or collaborative work. Such schools are restricting classroom use of broadband applications like streaming video to preserve bandwidth. As the Benton Foundation explains:

Distance learning over broadband is a distant dream. Online curricula is offline. Teachers are insufficiently trained to use technology in their classrooms, so that whatever technology is available to them languishes. Students are taught the basic 3

---

<sup>80</sup> Ian Quillen, “Bandwidth Demands Rise as Schools Move to Common Core,” *Education Week: Digital Directions*, October 17, 2012, October 17, 2012, Vol. 6. at 19-20.

<http://www.edweek.org/dd/articles/2012/10/17/01bandwidth.h06.html>.

Fox, *et al.*, 2012, “The Broadband Imperative: Recommendations to Address K–12 Education Infrastructure Needs,” Washington D.C.: State Educational Technology Directors Association (SETDA).

[http://www.setda.org/c/document\\_library/get\\_file?folderId=353&name=DLFE-1515.pdf](http://www.setda.org/c/document_library/get_file?folderId=353&name=DLFE-1515.pdf). See also Center for Digital Education, “Preparing for the Common Core State Standards: School districts face an opportunity to reinvest in network infrastructure,” at 5.

[http://images.erepublic.com/documents/CDE12+STRATEGY+Comcast\\_V.pdf](http://images.erepublic.com/documents/CDE12+STRATEGY+Comcast_V.pdf).

Rs, as required by the No Child Left Behind Act, but not the digital skills that will enable them to translate those 3 Rs into success in today's Information Age.<sup>81</sup>

"The content-rich world in which we live requires bandwidth to view it."<sup>82</sup> Yet, according to the 2008 America's Digital Schools report, 37 percent of school districts anticipate a problem obtaining sufficient bandwidth and the majority have already implemented policies to conserve bandwidth by limiting student Internet use.<sup>83</sup> Although a 2010 FCC survey of e-Rate funded schools found the majority of respondents had some level of Internet access, nearly 80 percent of respondents reported insufficient bandwidth for educational needs.<sup>84</sup> Despite these problems, Internet proficiency is assumed at the college level, leaving many children at an educational disadvantage. These problems will only grow as more schools adopt more bandwidth-intensive practices.

#### 4.4.2.1 Electronic Textbooks

In no more than a few years more, hard-copy text books will cease to be printed in favor of electronic textbooks. This process is underway in Korea with a fixed deadline. The U.S. Federal Communications Commission (FCC) has challenged the private sector to enable this process by 2015.<sup>85</sup> At a recent conference, FCC Chairman Julius Genachowski urged the nation to "step up [its] efforts to realize the promise of this new technology in the U.S."<sup>86</sup> States around the country are seizing this challenge.

In September 2012, the California state Senate approved SB 1052 and SB 1053, requiring the University of California, the California State University, the California Community Colleges, and other private institutions to find or develop open education resources for students. The legislation is intended to reduce textbook costs for students, saving students

---

<sup>81</sup> Jonathan Rintel, "An Action Plan for America: Using Technology and Innovation to Address Our Nation's Critical Challenges," The Benton Foundation, 2008, at 20.

[http://www.benton.org/initiatives/broadband\\_benefits/action\\_plan](http://www.benton.org/initiatives/broadband_benefits/action_plan).

<sup>82</sup> Edwin Wargo, "2008 Digital Schools Report and Bandwidth," *The Brute Thing*, May 16, 2008.

<http://edtecheconomics.blogspot.com/2008/05/ed-tech-trends-report.html>.

<sup>83</sup> Meris Stansbury, "Researchers Identify Key Ed-Tech Trends," *eSchoolNews*, May 15, 2008.

<http://www.eschoolnews.com/2008/05/15/researchers-identify-key-ed-tech-trends/>. (Summarizing Thomas W. Greaves and Jeanne Hayes, "America's Digital Schools Report 2008: The Six Trends to Watch.")

<sup>84</sup> Fox, *et al.*, 2012, "The Broadband Imperative: Recommendations to Address K-12 Education Infrastructure Needs," Washington D.C.: State Educational Technology Directors Association (SETDA), at 2.

[http://www.setda.org/c/document\\_library/get\\_file?folderId=353&name=DLFE-1515.pdf](http://www.setda.org/c/document_library/get_file?folderId=353&name=DLFE-1515.pdf).

<sup>85</sup> "FCC Chairman Genachowski Joins Secretary of Education Duncan to Unveil New 'Digital Textbook Playbook,' A Roadmap for Educators to Accelerate the Transition to Digital Textbooks," News Release, Federal Communications Commission.

[http://transition.fcc.gov/Daily\\_Releases/Daily\\_Business/2012/db0201/DOC-312244A1.pdf](http://transition.fcc.gov/Daily_Releases/Daily_Business/2012/db0201/DOC-312244A1.pdf).

<sup>86</sup> Katie Ash, March 29, 2012, "U.S. Officials Tackle National Adoption of Digital Textbooks," *Education Week* (Blog), March 29, 2012.

[http://blogs.edweek.org/edweek/DigitalEducation/2012/03/fcc\\_lead\\_and\\_doe\\_discuss\\_digit.html](http://blogs.edweek.org/edweek/DigitalEducation/2012/03/fcc_lead_and_doe_discuss_digit.html).

at participating universities as much as \$1,500 annually. The bills are currently awaiting consideration by the California State Assembly.<sup>87</sup> Such initiatives would not be possible without sufficient bandwidth to support online viewing.

#### 4.4.2.2 Online Testing

A growing number of states are beginning to administer tests to their students online. SETDA reports that at least 33 states are already delivering at least one test via technology. Moreover, the Department of Education is advocating for a greater use of online testing through the Common Core State Standards initiative, which requires schools in 46 states and the District of Columbia to “administer ‘next generation’ assessments almost exclusively online.”<sup>88</sup>

The new assessments for the “Smarter Balanced” and “Partnership for the Assessment of College and Career Readiness” (PARCC) consortia will be conducted electronically by 2014. Moreover, national guidelines require that once such online assessments are implemented, all students in a grade must take the tests (which will include high-definition videos and sound files) simultaneously,<sup>89</sup> leading to greater network traffic during testing.

In fact, the Center for Digital Education explains, “adherence to Common Core guidelines will force school districts across the nation to rethink the way they handle networking and computing in a number of mission-critical areas.”<sup>90</sup> Because digital testing entails large numbers of students working online simultaneously, it is a function that simply cannot be accommodated, even in a small school, over copper-based Internet access.

---

<sup>87</sup> Levon Massian, June 3, 2012, “State Senate Advances Bills that would Create Free Online Textbook Library,” *The Daily Californian*, June 1, 2012.

<http://www.dailycal.org/2012/06/01/state-senate-advances-bills-that-would-create-free-online-textbook-library/>.

<sup>88</sup> Ian Quillen, “Bandwidth Demands Rise as Schools Move to Common Core,” *Education Week: Digital Directions*, October 17, 2012, Vol. 6. at 19-20.

<http://www.edweek.org/dd/articles/2012/10/17/01bandwidth.h06.html>.

<sup>89</sup> Center for Digital Education, “Preparing for the Common Core State Standards: School districts face an opportunity to reinvest in network infrastructure,” at 2.

[http://images.erepublic.com/documents/CDE12+STRATEGY+Comcast\\_V.pdf](http://images.erepublic.com/documents/CDE12+STRATEGY+Comcast_V.pdf)

<sup>90</sup> *Id.*

Figure 10: Networking Upgrades Needed for Online Assessments<sup>91</sup>

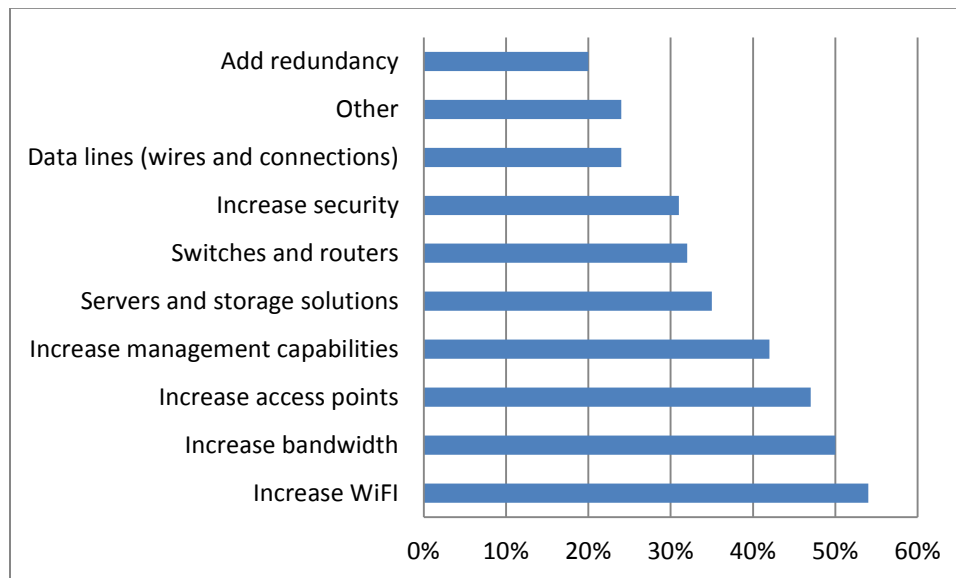

#### 4.4.2.3 One-to-One Computer Programs

American schools are migrating to one-to-one computer programs (also known as “ubiquitous computing”), whereby each student and teacher has one Internet-connected wireless computing device for use both in the classroom and at home. A 2006 survey found that 31 percent of superintendents are implementing ubiquitous computing in at least one grade, up from an historical average of 4 percent. Moreover, over 75 percent of superintendents recognized the potential benefits of one-to-one computing, agreeing with the statement that “ubiquitous technology can reduce the time, distance, and cost of delivering information directly to students and that teachers can spend substantially more one-on-one time with each student and personalize the education experience to each student’s needs.”<sup>92</sup>

By 2007, 78.7 percent of U.S. school districts reported moderate to significant improvement in one-to-one computing programs,<sup>93</sup> with potentially significant benefits for student learning. A 2006 report by America’s Digital Schools found that one-to-one computing programs correlated with increased student retention and attendance,

<sup>91</sup> Center for Digital Education, “Preparing for the Common Core State Standards: School districts face an opportunity to reinvest in network infrastructure,” at 4

(<http://images.erepublic.com/documents/CDE12+STRATEGY+Comcast V.pdf>)

<sup>92</sup> “America’s Digital Schools 2006: A Five-Year Forecast,” The Greaves Group and The Hayes Connection, at 15, 18. <http://www.ads2006.net/ads2006/pdf/ADS2006KF.pdf>.

<sup>93</sup> Meris Stansbury, “Researchers Identify Key Ed-Tech Trends,” eSchoolNews, May 15, 2008. <http://www.eschoolnews.com/2008/05/15/researchers-identify-key-ed-tech-trends/>.

improved writing skills, and reduced disciplinary problems.<sup>94</sup> As Michael Davino, Superintendent of Schools in Springfield, New Jersey explains, “[a] wireless laptop program provides up-to-date information, access to virtual experiences, instant feedback, individualized attention for all learning styles, student independence, and constant practice. And it’s highly adaptable to individual, small group, or whole class instruction.”<sup>95</sup> To accommodate such programs, SETDA recommends that a school upgrade its network to a 50 Kbps/ student/staff broadband connection.<sup>96</sup>

#### **4.4.2.4 Bring Your Own Device (BYOD) Initiatives**

Schools are also launching “bring your own device” (BYOD) initiatives. While this leverages limited school infrastructure (by requiring students to provide their own), it raises a number of information technology challenges, including “information security and privacy, support costs, network capacity and bandwidth.”<sup>97</sup> Of particular concern, BYOD initiatives are very bandwidth intensive. A recent mobile learning report found that about half of high school students and 40 percent of middle school students have a smartphone or tablet. This represents a 400 percent increase from 2007.<sup>98</sup> Assuming similar growth over the next five years, student use of mobile devices will increase the demand on K–12 networks.

Bailey Mitchell, chief technology and information officer of Georgia’s Forsyth County Schools, witnessed the impact of such growth on the school’s network, explaining that the County did “not have adequate infrastructure to enable an environment where potentially every other or every student has a device.” There, the number of devices increased from 10,000 to 19,000 in a single year. The growth exceeded network capacity and “student instruction was interrupted.” This failure led to a three-fold expansion of network capacity (1.3 Gbps to the Internet and 2 Gbps to wide area networks). Mitchell explains, “We’ve been able to justify that expense because when the network blips, it’s such an impact on

---

<sup>94</sup> “America’s Digital Schools 2006: A Five-Year Forecast,” The Greaves Group and The Hayes Connection, at 15. <http://www.ads2006.net/ads2006/pdf/ADS2006KF.pdf>.

<sup>95</sup> *Id.* at 18.

<sup>96</sup> Fox, *et al.*, 2012, “The Broadband Imperative: Recommendations to Address K–12 Education Infrastructure Needs,” Washington D.C.: State Educational Technology Directors Association (SETDA), at 4. [http://www.setda.org/c/document\\_library/get\\_file?folderId=353&name=DLFE-1515.pdf](http://www.setda.org/c/document_library/get_file?folderId=353&name=DLFE-1515.pdf).

<sup>97</sup> Bob Violino, Aug. 21, 2012, Community College Times, “BYOD: Bring your own devices to campus” (<http://www.communitycollegetimes.com/Pages/Technology/BYOD-Bring-your-own-devices-to-campus.aspx>).

<sup>98</sup> Tanya Roscorla, Dec. 10, 2012, “5 Ways to Prepare Schools for Bring Your Own Device,” Center for Digital Education, December 10, 2012. <http://www.centerdigitaled.com/news/5-Ways-to-Prepare-Schools-for-Bring-Your-Own-Device.html>.



instruction that it's absolutely unacceptable." He cautions that IT directors will need to anticipate such needs when students are allowed to use their devices throughout the day.<sup>99</sup>

#### 4.4.2.5 Expanded Course Offerings

Many schools are using the Internet to expand course offerings. For instance, in Greenville, South Carolina, students are enrolling in an online Latin course taught by a teacher at another school in the district. Elsewhere, students can use the Internet to take higher level or better-quality courses than those available at their home schools.<sup>100</sup> The Greaves Group has found that many schools are even offering core courses over the Internet, with vocational technology (91 percent) leading, followed by science (78 percent) and social studies (76 percent). Online learning is often used for advanced-placement courses, including art and music (38 percent), math (35 percent), and science (31 percent), which may not have sufficient student enrollment to support a live course.<sup>101</sup> Online education enrollment has grown exponentially. In fact, the Innosight Institute reports that in 2000, roughly 45,000 K–12 students had taken an online course. By 2009, more than 3 million K–12 students had done so. Innosight predicts that 50 percent of high school courses will be delivered partially online by 2019.<sup>102</sup> Beyond K–12, online learning is growing in favor because it saves students time and money.<sup>103</sup>

The Internet helps break down the walls of the classroom, allowing students to participate in virtual fieldtrips and better visualize their lessons. Students are going online and “touring the Smithsonian National Air and Space Museum, experiencing a tribal dance in Africa, or scouring the depths of the Pacific Ocean in a submarine.” Users are exploring the digital archives at the Library of Congress and collaborating with students, professors and government officials in other states and around the world.<sup>104</sup> The State Educational Technology Directors Association envisions a classroom environment where “Internet-based educational technologies and practices” are fully “integrated into the curriculum.” In such a scenario, students “access rich, multimedia-enhanced educational

---

<sup>99</sup> Tanya Roscorla, “Bring Your Own Device Prompts School Infrastructure Investments,” Center for Digital Education, March 13, 2012. <http://www.centerdigitaled.com/classtech/BYOD-Forsyth-Infrastructure.html>.

<sup>100</sup> Jonathan Rintels, “An Action Plan for America: Using Technology and Innovation to Address Our Nation’s Critical Challenges,” The Benton Foundation, 2008, at 21. [http://www.benton.org/initiatives/broadband\\_benefits/action\\_plan](http://www.benton.org/initiatives/broadband_benefits/action_plan).

<sup>101</sup> “America’s Digital Schools 2006: A Five-Year Forecast,” The Greaves Group and The Hayes Connection, at 19. <http://www.ads2006.net/ads2006/pdf/ADS2006KF.pdf>.

<sup>102</sup> Michael Horn and Heather Staker, Jan. 2011, “The Rise of K–12 Blended Learning,” Innosight Institute, January 27, 2011. <http://www.innosightinstitute.org/education-blog/the-rise-of-k-12-blended-learning/>

<sup>103</sup> Collette Boothe, “The Need for Data,” Center for Digital Education, Jan. 8, 2009. <http://www.centerdigitaled.com/edtech/The-Need-for-Data.html>.

<sup>104</sup> Jonathan Rintels, “An Action Plan for America: Using Technology and Innovation to Address Our Nation’s Critical Challenges,” The Benton Foundation, 2008, at 21. [http://www.benton.org/initiatives/broadband\\_benefits/action\\_plan](http://www.benton.org/initiatives/broadband_benefits/action_plan).

content from the Internet” on personal laptops, post both audio and video content to school learning management systems, access e-textbooks and assignments online, collaborate with other students both at their own school and around the world, participate in fieldtrips to distant locations, and complete online assessments. Such technology-rich experiences require greater bandwidth in the classrooms. In fact, SETDA asserts that this whole-curricula approach requires schools to provide a 100 Kbps per student/staff broadband connection.<sup>105</sup>

#### **4.4.2.6 Benefits of Broadband Applications in Schools**

Research by the International Society for Technology in Education and the Consortium for School Networking confirms that broadband applications in the schools have many benefits. In particular, technology has:

- Led to measurable improvements in school performance (as measured on the Adequate Yearly Progress Tests under the No Child Left Behind Act of 2001).
- Improved attendance, decreased dropout rates, increased graduation rates, and allowed increased parental involvement.
- Improved school efficiency and productivity.
- Helped teachers satisfy professional requirements by helping develop lesson plans and providing continuing education opportunities.
- Enhanced students’ problem-solving and independent-thinking skills.
- Enabled schools to meet the needs of special education children.
- Increased equity and access in education by creating learning opportunities for geographically isolated students.
- Improved workforce skills.<sup>106</sup>

Case studies bear out these benefits. For instance, elementary school students in the “Enhancing Missouri’s Instructional Networked Teaching Strategies” (eMINTS) program consistently scored higher on standardized achievement tests than students who did not have access to the same technology. Participants’ classrooms are equipped with a teacher’s

---

<sup>105</sup> Fox, *et al.*, 2012, “The Broadband Imperative: Recommendations to Address K–12 Education Infrastructure Needs,” Washington D.C.: State Educational Technology Directors Association (SETDA), at 4.  
[http://www.setda.org/c/document\\_library/get\\_file?folderId=353&name=DLFE-1515.pdf](http://www.setda.org/c/document_library/get_file?folderId=353&name=DLFE-1515.pdf).

<sup>106</sup> “Why Technology in Schools?” Ed Tech Action Network.  
<http://www.edtechactionnetwork.org/why-technology-in-schools>.

desktop computer and laptop computer, a scanner, a color printer, a digital camera, an interactive white board, a digital projector, and one computer for every two students. In New York, middle and high school students enrolled in the “Points of View media project” used broadband to access museums and historical collections, streaming video and video conferencing, and primary documents to explore the Theodore Roosevelt era. Seventy-five percent of program participants reported that they learned more than they would have from a traditional class.<sup>107</sup>

#### 4.4.3 HIGH BANDWIDTH NEEDS AMONG LIBRARIES

In the libraries sector, TechSoup, a non-profit that provides technical assistance to libraries with the support of the Gates Foundation, notes that the amount of bandwidth required depends on the number of users and computers at a library facility.<sup>108</sup> As a TechSoup/Colorado State Library graphic illustrates (see below), a T-1 used by three library patrons simultaneously will enable website loading in five seconds and a book download in 15 seconds.<sup>109</sup> While not optimal, these speeds may be acceptable. Times will multiply, however, as the number of simultaneous users multiply. As a result, a library serving 30 simultaneous users would require at least 45 Mbps to enable website loading in five seconds and a book download in 15 seconds. Video applications will require three times that bandwidth.

---

<sup>107</sup> “Ed Tech and Student Achievement,” Ed Tech Action Network.

[http://www.edtechactionnetwork.org/student\\_achieve.html](http://www.edtechactionnetwork.org/student_achieve.html).

<sup>108</sup> “Bandwidth Management,” TechSoup for Libraries.

<http://www.techsoupforlibraries.org/planning-for-success/networking-and-security/bandwidth-managemen>

[t](#); see also Kieran Hixon, “Broadband Basics for Public Libraries,” TechSoup and Colorado State Library, Presentation, January 15, 2013,

<http://www.techsoupforlibraries.org/blog/broadband-basics-webinar-follow-up>;

<http://ipac.umd.edu/survey/analysis/broadband-public-libraries>;

<http://plinternetsurvey.org/sites/default/files/publications/BroadbandBrief2012.pdf>;

[http://www.webjunction.org/documents/illinois/Broadband\\_Calculator.html](http://www.webjunction.org/documents/illinois/Broadband_Calculator.html) (a broadband bandwidth calculator for libraries that uses speed of website loading as a guide to bandwidth needs).

<sup>109</sup> “Bandwidth Management,” TechSoup for Libraries.

<http://www.techsoupforlibraries.org/planning-for-success/networking-and-security/bandwidth-managemen>  
[t](#).

Figure 11: Download Speeds for Libraries<sup>110</sup>

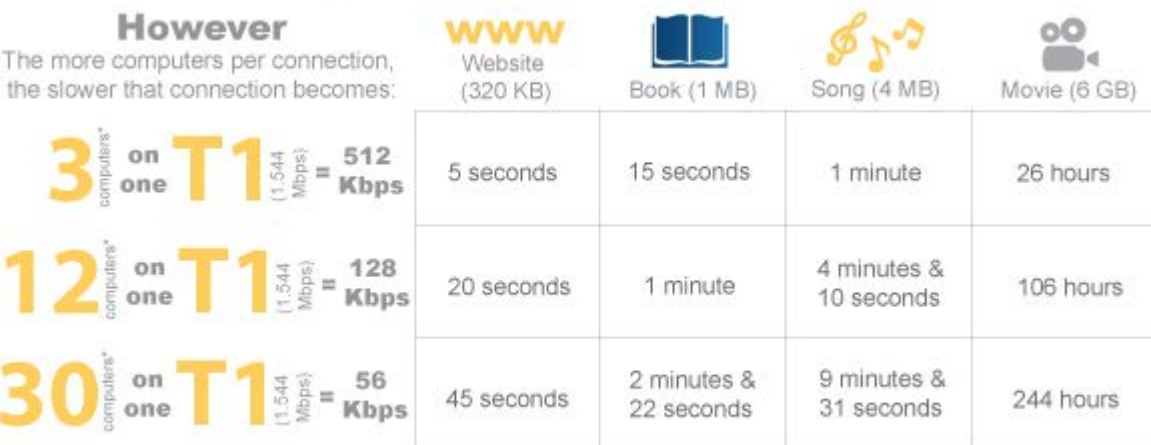
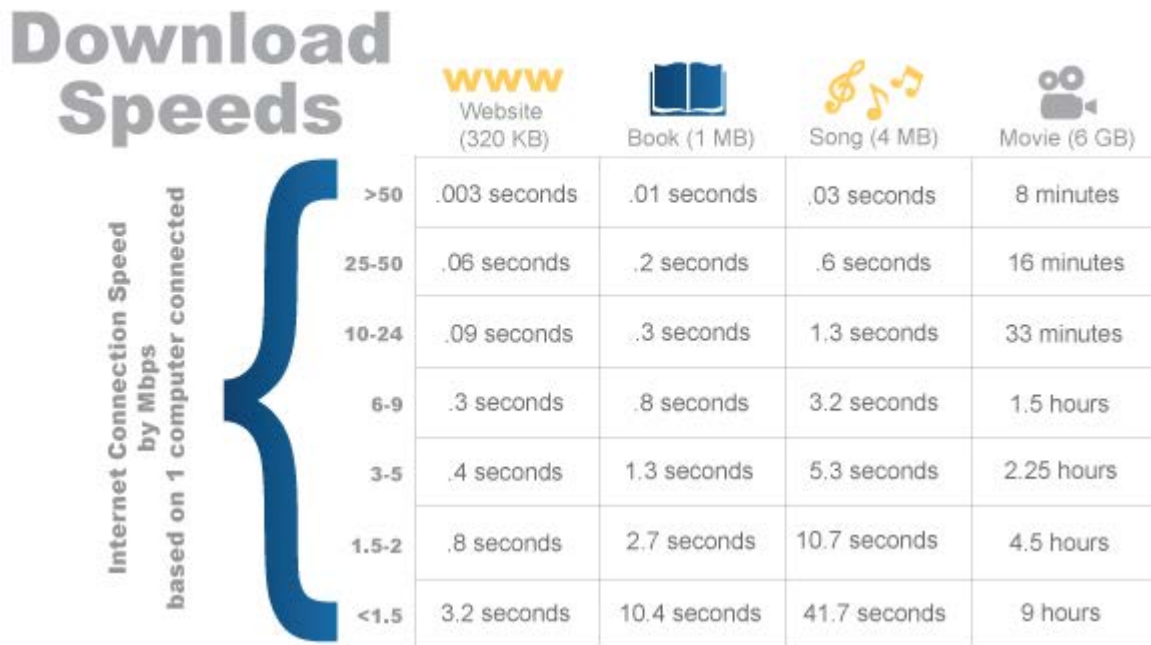

\*For connection purposes, a computer includes desktops, laptops, tablets, and all devices on the connection via wired or wireless access.

For more information: [www.broadbandmap.gov](http://www.broadbandmap.gov)

Source: TechSoup / Colorado State Library

Libraries have long served as “a premier Internet access provider in the continually evolving online culture.”<sup>111</sup> In fact, a 2008 study found public libraries provided the only

<sup>110</sup> Kieran Hixon, “Broadband Basics for Public Libraries,” TechSoup and Colorado State Library, Presentation, January 15, 2013. <http://www.techsoupforlibraries.org/blog/broadband-basics-webinar-follow-up>

free Internet access in 72.5 percent of U.S. communities nationwide. This number rose to 82 percent in rural communities.<sup>112</sup> A 2012 study reaffirms the role of libraries as the sole public provider of free Internet access in the majority (64.5 percent) of American communities.<sup>113</sup>

Public libraries serve a variety of functions. They offer desktop workstations for Internet use, technical training, and access to locally relevant content. Public library Internet access is used for an array of reasons—job seeking, educational research, travelers looking to keep in touch with their families, and emergency information. Libraries play a key role in providing access, assistance and training through e-government sites and services. Public libraries also provide a safety net during disasters when Internet access may be limited elsewhere.<sup>114</sup> In light of this wide array of services, “the role of the public library as a stable Internet provider cannot be overestimated.”<sup>115</sup>

Public libraries, however, are facing significant capacity constraints. Bandwidth requirements are growing as public use expands and matures, but libraries are unable to keep up. As Bertot, McClure, and Jaeger report:

Libraries may be struggling to meet demands as a result of a combination of factors such as the limits on physical space in libraries, the increasing complexity of Internet content, the continual costs of Internet access and computer maintenance, the inherent limitations of the telecommunications grid, and the rising demands for bandwidth, processing speed, and numbers of workstations, among other factors.<sup>116</sup>

In recent years, libraries have expanded wireless access to allow for a larger number of users at limited workstations. While this allows more users to get online, it also creates additional traffic on limited bandwidth.<sup>117</sup>

---

<sup>111</sup> Marijke Visser and Mary Alice Ball, Dec. 2010, “The Middle-mile: The Role of the Public Library in Ensuring Access to Broadband,” *Information Technology and Libraries*, at 193.

<http://www.ala.org/lita/ital/sites/ala.org.lita.ital/files/content/29/4/visser.pdf>.

<sup>112</sup> *Id.* at 191.

<sup>113</sup> Information Policy and Access Center (IPAC), 2012, “Public Libraries and Broadband.”

<http://www.plinternetsurvey.org/analysis/public-libraries-and-broadband>.

<sup>114</sup> John Carlo Bertot, Charles R. McClure, and Paul T. Jaeger, 2008, “The Impacts of Free Public Internet Access on Public Library Patrons and Communities,” *Library Quarterly* 78, no. 3, at 286.

<http://mcclure.ii.fsu.edu/publications/2008/The%20impacts%20of%20free%20public%20Internet%20access%20on%20public%20library%20patrons%20and%20communities.pdf>

<sup>115</sup> Marijke Visser and Mary Alice Ball, Dec. 2010, “The Middle-mile: The Role of the Public Library in Ensuring Access to Broadband,” *Information Technology and Libraries*, at 192.

<sup>116</sup> John Carlo Bertot, Charles R. McClure, and Paul T. Jaeger, 2008, “The Impacts of Free Public Internet Access on Public Library Patrons and Communities,” *Library Quarterly* 78, no. 3, at 297.

<sup>117</sup> *Id.* at 292.

Libraries are seeking ways to add bandwidth as applications become more intensive (e.g., streaming video, online communications, social networking tools), yet this growing need is seldom accompanied by a corresponding increase in budget or capacity. The Information Policy and Access Center (iPAC) reports that libraries have steadily increased their bandwidth capacity in recent years. While only 12.3 percent of public libraries reported speeds greater than 10 mbps in 2008-2009, 31.7 percent of public libraries have reported speeds at this level in 2011-2012 (see Figure 12).<sup>118</sup> While bandwidth has increased in recent years, however, this growth has been outpaced by the increase in bandwidth-requiring applications. Consequently, despite supposed high-speed connections, users may experience “slow connectivity and near dial-up speeds.”<sup>119</sup>

Figure 12: Public Library Internet Connectivity Speeds (2011-2012)<sup>120</sup>

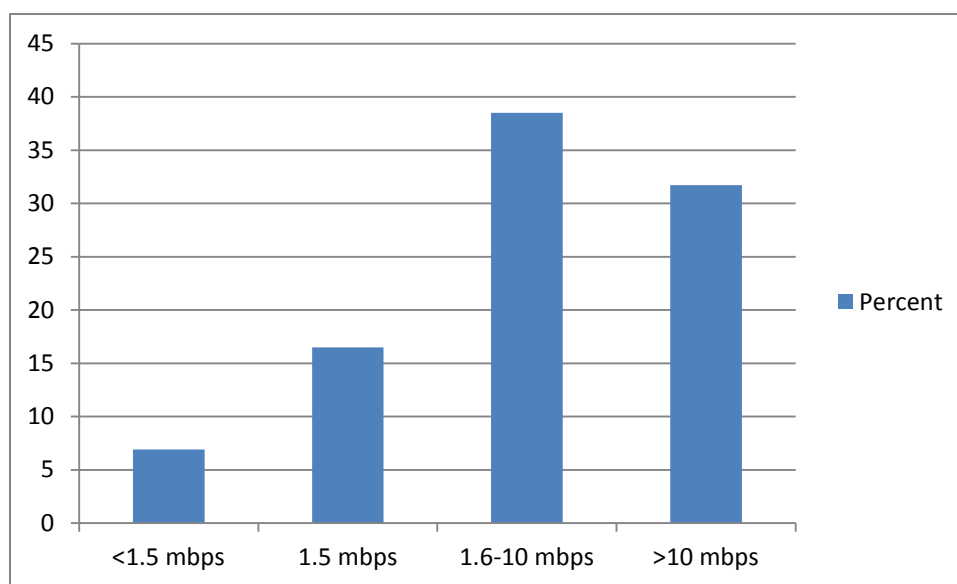

Data from the Public Libraries and the Internet studies reveal a “disconnect’ between what their communities expect and the levels of Internet access that they are able to provide to their communities.”<sup>121</sup> In fact, a 2012 study found that 41.1 percent of public libraries report that their connection speeds are insufficient to meet patron needs some or all of the

<sup>118</sup> “Public Libraries and Broadband,” *Public Library Funding and Technology Survey*, Information Policy and Access Center, 2012. [http://ipac.umd.edu/sites/default/files/publications/BroadbandBrief2012\\_0.pdf](http://ipac.umd.edu/sites/default/files/publications/BroadbandBrief2012_0.pdf).

<sup>119</sup> “Broadband and Public Libraries,” Information Policy and Access Center (IPAC), 2012. <http://www.plinternetsurvey.org/analysis/public-libraries-and-broadband>.

<sup>120</sup> “Public Libraries and Broadband,” *Public Library Funding and Technology Survey*, Information Policy and Access Center, 2012. [http://ipac.umd.edu/sites/default/files/publications/BroadbandBrief2012\\_0.pdf](http://ipac.umd.edu/sites/default/files/publications/BroadbandBrief2012_0.pdf).

<sup>121</sup> John Carlo Bertot, Charles R. McClure, and Paul T. Jaeger, 2008, “The Impacts of Free Public Internet Access on Public Library Patrons and Communities,” *Library Quarterly* 78, no. 3, at 287.

time.<sup>122</sup> While this is an improvement from nearly 58 percent reporting inadequate speeds in a similar 2007 survey,<sup>123</sup> it reveals that additional bandwidth is needed. The data suggests that libraries have reached an “infrastructure plateau for provision of and access to Internet services.”<sup>124</sup> This problem is only compounded by the economic downturn, as more people depend on libraries for free Internet access. As a consequence, infrastructure limits are being hit precisely at a time when consumer demand for library services is increasing.

While libraries have long served the role of “community guarantor of free public Internet access,”<sup>125</sup> they cannot meet these needs without public support. As Visser and Ball acknowledge, “[o]vercoming the challenges successfully will require support on the local, state, and federal level.”<sup>126</sup> Indeed, “[w]hat else can the federal government fund that simultaneously serves so many educational, economic, employment, communication, government, and emergency preparedness functions?”<sup>127</sup>

While slightly more than half (58.3 percent) of public libraries reported in 2010-2011 that their broadband connection meets patron needs, more libraries are expected to report insufficient connections in coming years unless funding to improve broadband infrastructure is increased. Indeed, “[a]s more people rely on public libraries for Internet access, and as more of these people use a greater range of high bandwidth education, government, and entertainment content, the bandwidth capacity of libraries becomes an increasingly significant issue.”<sup>128</sup>

Many libraries are seeking to expand their use and meet access demands by establishing Wi-Fi networks. However, the Information Policy and Access Center (iPAC) reports that in the vast majority of libraries with wireless access (82.3 percent), wireless users are sharing the same bandwidth and connection with existing workstations. As a consequence, libraries are increasing “connection capacity at the expense of connection quality.” This growth results in more users drawing on limited bandwidth. iPAC explains:

---

<sup>122</sup> “Broadband and Public Libraries,” Information Policy and Access Center (IPAC), 2012.

<http://www.plinternetsurvey.org/analysis/public-libraries-and-broadband>.

<sup>123</sup> Marijke Visser and Mary Alice Ball, Dec. 2010, “The Middle-mile: The Role of the Public Library in Ensuring Access to Broadband,” *Information Technology and Libraries*, at 191.

<sup>124</sup> John Carlo Bertot, Charles R. McClure, and Paul T. Jaeger, 2008, “The Impacts of Free Public Internet Access on Public Library Patrons and Communities,” *Library Quarterly* 78, no. 3, at 297.

<sup>125</sup> *Id.* at 299.

<sup>126</sup> Marijke Visser and Mary Alice Ball, Dec. 2010, “The Middle-mile: The Role of the Public Library in Ensuring Access to Broadband,” *Information Technology and Libraries*, at 191-92.

<sup>127</sup> John Carlo Bertot, Charles R. McClure, and Paul T. Jaeger, 2008, “The Impacts of Free Public Internet Access on Public Library Patrons and Communities,” *Library Quarterly* 78, no. 3, at 300.

<sup>128</sup> “Survey: Broadband and Public Libraries,” Information Policy and Access Center (IPAC), 2012.

<http://ipac.umd.edu/survey/analysis/broadband-public-libraries>.

As an example, take a common scenario: a public library has 15 public access workstations in constant use; it offers Wi-Fi that supports another 10–15 simultaneous connections, typically in use; the library has a T-1 connection (1.5 Mbps or megabits per second leased line broadband service); and the Wi-Fi and public access workstations share the same connection. With up to 30 devices sharing the same 1.5 Mbps connection, the connection speed at the device level is the equivalent of dial-up service, severely affecting the quality of the user experience.<sup>129</sup>

It is unsustainable for libraries to increase the number of workstations and use of their Wi-Fi networks without a concomitant increase in connection speed. Yet, this is precisely what is occurring. In fact, though 74.3 percent of libraries reported that they did not increase their connection speed from 2011–2012, 60.1 percent reported an increase in the use of their public access workstations and 74.9 percent reported an increase in the use of their Wi-Fi network. “If these trends continue, we can expect the demands on public library networks to exceed capacity in the near future, especially at urban public libraries.”<sup>130</sup>

#### 4.4.4 HIGH BANDWIDTH NEEDS IN THE HEALTH CARE SECTOR

According to the FCC, health care facilities’ broadband needs exceed 100 Mbps on a regular basis. As the FCC’s graphic demonstrates, medical applications such as image transfer (PACS) require 100 Mbps; that number will multiply by the number of simultaneous users of that application.

**Table 9: Bandwidth Required to Achieve Full Functionality of Health IT Applications**

Text-Only HER	Remote Monitoring	Basic e-mail + Web browsing	SD Video Conferencing	HD Video Conferencing	Image Transfer (PACS)
.025 Mbps	.5 Mbps	1.0 Mbps	2.0 Mbps	>10 Mbps	100 Mbps

Source: Federal Communications Commission<sup>131</sup>

Broadband technology can dramatically reduce health care expenses by providing the tools to remotely monitor patients, allow collaboration between medical professionals, facilitate the transfer of medical data and images, and increase access to emergency services in remote areas.<sup>132</sup> By one estimate, these services can lead to savings of \$165 billion per

---

<sup>129</sup> *Ibid.*

<sup>130</sup> *Ibid.*

<sup>131</sup> *Ibid.*

<sup>132</sup> Jonathan Rintel, “An Action Plan for America: Using Technology and Innovation to Address Our Nation’s Critical Challenges,” The Benton Foundation, 2008, at 15 (broadband can “revolutionize medical treatment”). [http://www.benton.org/initiatives/broadband\\_benefits/action\\_plan](http://www.benton.org/initiatives/broadband_benefits/action_plan). See also Carlton Doty, “Delivering Care Anytime, Anywhere; Telehealth Alters the Medical Ecosystem.” Forrester Research for the California



year.<sup>133</sup> "Always-on broadband" is "essential" for many of these applications and greatly improves others that "depend on uninterrupted real-time transmission."<sup>134</sup> While the economic benefits of telemedicine are undeniable, these applications require significant bandwidth, particularly for those that require streaming video and high-resolution diagnostic imaging. As the Healthcare Information and Management Systems Society explains, "[h]igh bandwidth is crucial in supporting the ever-expanding technical infrastructures prevalent throughout many of the nation's hospitals, clinics and doctor's offices." For instance, a T-1 internet connection could take as much as an hour to upload an image study to the network, whereas the same image can be moved in seconds using Internet2.<sup>135</sup>

Broadband allows users to access medical information online, avoiding costly trips to medical professionals. Approximately 20,000 health-related websites provide information to more than three-quarters of online Americans who access medical information over the Internet.<sup>136</sup> More than ten percent of broadband users use the Internet for this purpose on a given day.<sup>137</sup>

Broadband users also avoid scheduling (and driving) to multiple appointments by using the Internet to get a second opinion based on their medical records or by exchanging e-mails with their doctors. Notably, Kaiser Permanente reduced appointments with primary care physicians by 7 percent to 10 percent by allowing its enrollees to e-mail questions to their doctor through a secure messaging system.<sup>138</sup> Thirty-seven percent of Kentucky broadband

---

Healthcare Foundation, Nov. 2008; Telemedicine Association of Oregon, "Benefits of Telemedicine," Jan 16, 2004. <http://www.ortcc.org/PDF/BenefitsofTelemedicine.pdf>.

<sup>133</sup> Jonathan Rintels, "An Action Plan for America: Using Technology and Innovation to Address Our Nation's Critical Challenges," The Benton Foundation, 2008, at 15.

[http://www.benton.org/initiatives/broadband\\_benefits/action\\_plan](http://www.benton.org/initiatives/broadband_benefits/action_plan).

<sup>134</sup> Alexander H. Vo, "The Telehealth Promise: Better Health Care and Cost Savings for the 21st Century," University of Texas Medical Branch, May 2008, at 13.

<sup>135</sup> Healthcare Information and Management Systems Society, Sept. 17, 2009, FCC Broadband Workshop on Healthcare. <http://www.himss.org/policy/d/broadbandSummary.pdf>.

<sup>136</sup> Devon Herrick, Convenient Care and Telemedicine, National Center for Policy Analysis, NCPA Policy Report No. 305 (ISBN #1-56808-179-0), Nov. 2007, at 14; Jonathan Rintels, "An Action Plan for America: Using Technology and Innovation to Address Our Nation's Critical Challenges," The Benton Foundation, 2008, at 15-16. [http://www.benton.org/initiatives/broadband\\_benefits/action\\_plan](http://www.benton.org/initiatives/broadband_benefits/action_plan).

<sup>137</sup> Jonathan Rintels, "An Action Plan for America: Using Technology and Innovation to Address Our Nation's Critical Challenges," The Benton Foundation, 2008, at 16. ("On an average day, one in nine of those with a broadband connection uses it to research online medical information").

[http://www.benton.org/initiatives/broadband\\_benefits/action\\_plan](http://www.benton.org/initiatives/broadband_benefits/action_plan)

<sup>138</sup> Devon Herrick, Convenient Care and Telemedicine, National Center for Policy Analysis, NCPA Policy Report No. 305 (ISBN #1-56808-179-0), Nov. 2007, at 14.

users report that access to online information has saved them an average of 4.2 unnecessary trips for medical care in a single year.<sup>139</sup>

Telehealth holds particular promise for remote monitoring of chronic conditions. Nearly half of Americans (45 percent or 130 million people) suffer from at least one chronic condition, such as arthritis, asthma, Cancer, depression, diabetes, heart disease, and obesity. Combined, treatment of these conditions accounts for seventy five percent of healthcare spending—\$1.5 trillion annually.<sup>140</sup> Despite this enormous expense, most Americans with chronic conditions suffer from inadequate treatment. According to the National Center for Policy Analysis, less than one fourth of patients with high blood pressure control it adequately. Twenty percent of patients with Type-1 diabetes fail to see a doctor annually, with forty percent of diabetics failing to regularly monitor their blood sugar level or receive recommended annual retinal exams.<sup>141</sup>

Through remote monitoring, tens of millions of Americans can manage and address their chronic illness at dramatically lower cost. In fact, both the Benton Foundation and the University of Texas estimate that remote monitoring could lower hospital, drug and out-patient costs by 30 percent, reducing the length of hospital stays from 14.8 days to 10.9 days, office visits by 10 percent, home visits by 65 percent, emergency room visits by 40 percent, and hospital admissions by 63 percent.<sup>142</sup>

Remote monitoring applications are incredibly varied. Patients with chronic obstructive pulmonary disease can improve lung function with the use an inhaler and monitor airflow to and from their lungs with a spirometer, lowering hospital readmissions to 49 percent as compared to 67 percent for patients lacking home monitoring. Similarly, remote monitoring of congestive heart failure patients cut re-hospitalizations in half.<sup>143</sup> Glucose

---

<sup>139</sup> Steven S. Ross and Masha Zager, "Fiber to the Home Is Green Technology," *Broadband Properties*, Jan/ Feb 2009, at 31. [http://www.bbpmag.com/2009issues/jan09/BBP\\_JanFeb09\\_CoverStory.pdf](http://www.bbpmag.com/2009issues/jan09/BBP_JanFeb09_CoverStory.pdf).

<sup>140</sup> Partnership to Fight Chronic Disease, 2008 Almanac of Chronic Disease, at 7 (Foreword by Richard Carmona, 17th U.S. Surgeon General). [http://www.fightchronicdisease.org/pdfs/PFCD\\_FINAL\\_PRINT.pdf](http://www.fightchronicdisease.org/pdfs/PFCD_FINAL_PRINT.pdf).

<sup>141</sup> Devon Herrick, *Convenient Care and Telemedicine*, National Center for Policy Analysis, NCPA Policy Report No. 305 (ISBN #1-56808-179-0), Nov. 2007, at 8.

<sup>142</sup> Jonathan Rintels, "An Action Plan for America: Using Technology and Innovation to Address Our Nation's Critical Challenges," The Benton Foundation, Nov. 2008, at 16. [http://www.benton.org/initiatives/broadband\\_benefits/action\\_plan](http://www.benton.org/initiatives/broadband_benefits/action_plan).

<sup>143</sup> Devon Herrick, *Convenient Care and Telemedicine*, National Center for Policy Analysis, NCPA Policy Report No. 305 (ISBN #1-56808-179-0), Nov. 2007, at 16. *See also* Jonathan Rintels, "An Action Plan for America: Using Technology and Innovation to Address Our Nation's Critical Challenges," The Benton Foundation, Nov. 2008, at 16 (discussing a New York case study that reduced health care costs for home-bound patients with congestive heart failure to cut overall health care costs by 41 percent). [http://www.benton.org/initiatives/broadband\\_benefits/action\\_plan](http://www.benton.org/initiatives/broadband_benefits/action_plan).

Meter Cell Phones allow diabetics to remotely monitor blood-sugar levels.<sup>144</sup> Diabetics in Pennsylvania using such home-monitoring systems were able to reduce hospitalization costs by more than 60 percent from a control group with traditional in-person nurse visits.<sup>145</sup> The Veterans Administration reports similar savings from its home-monitoring system, which has reduced emergency room visits by 40 percent and hospital admissions by 63 percent.<sup>146</sup> Remote monitoring holds particular promise for the elderly, by allowing them to defer or avoid institutionalization, thereby enhancing quality of life and reducing medical costs.

Broadband can also reduce transportation costs between medical facilities by allowing doctors to monitor patients and collaborate remotely. The potential savings are dramatic. The Benton Foundation estimates that telehealth technologies can prevent:

- Thirty-nine percent (850,000) of transports between emergency departments, with an annual savings of \$537 million;
- Forty-three percent (40,000) of transports from correctional facilities to emergency departments and 79 percent (543,000) of transports from correctional facilities to physician office visits, with an annual savings of \$280 million;
- Fourteen percent (387,000) of transports from nursing facilities to emergency departments and 68 percent (6.87 million) of transports from nursing facilities to physician office visits, with an annual savings of \$806 million.<sup>147</sup>

The adoption of Electronic Medical Records (EMR) will require robust broadband connectivity, which will help to avoid inefficiencies, with projected savings of up to \$81 billion annually—or \$670 per household.<sup>148</sup> The use of EMR systems is expected to grow

---

<sup>144</sup> Kathy Brown, Senior Vice President for Public Policy Development and Corporate Responsibility Verizon Communications, "Using Broadband to Promote Energy Efficiency."

[http://www.uschamber.com/bcl/resources/newsletter/2008/0804\\_verizon](http://www.uschamber.com/bcl/resources/newsletter/2008/0804_verizon).

<sup>145</sup> Jonathan Rintels, "An Action Plan for America: Using Technology and Innovation to Address Our Nation's Critical Challenges," The Benton Foundation, Nov. 2008, at 15.

[http://www.benton.org/initiatives/broadband\\_benefits/action\\_plan](http://www.benton.org/initiatives/broadband_benefits/action_plan).

<sup>146</sup> *Id.*

<sup>147</sup> Jonathan Rintels, "An Action Plan for America: Using Technology and Innovation to Address Our Nation's Critical Challenges," The Benton Foundation, Nov. 2008, at 16.

[http://www.benton.org/initiatives/broadband\\_benefits/action\\_plan](http://www.benton.org/initiatives/broadband_benefits/action_plan); Alexander H. Vo, "The Telehealth Promise: Better Health Care and Cost Savings for the 21st Century," University of Texas Medical Branch, May 2008, at 2.

<sup>148</sup> Jonathan Rintels, "An Action Plan for America: Using Technology and Innovation to Address Our Nation's Critical Challenges," The Benton Foundation, Nov. 2008, at 18 (citing Rand Health, "Extrapolating Evidence of Health Information Technology Savings," 2005 Public Medical Research data from the National Health

dramatically in the next two years. While such systems have existed in some form for more than 30 years, as of 2006, only 10 percent of U.S. hospitals had a fully integrated system.<sup>149</sup> By 2007, the Center for Disease control reports that 34.8 percent of office-based physicians reported some EMR use. By 2009, EMR adoption had increased to 48.3 percent of office-based practices.<sup>150</sup> This growth is anticipated to continue. In fact, the Administration has announced a goal of 100 percent utilization of electronic records by 2014.<sup>151</sup>

Figure 13: Percentage of Office-Based Physicians with Electronic Medical Records<sup>152</sup>

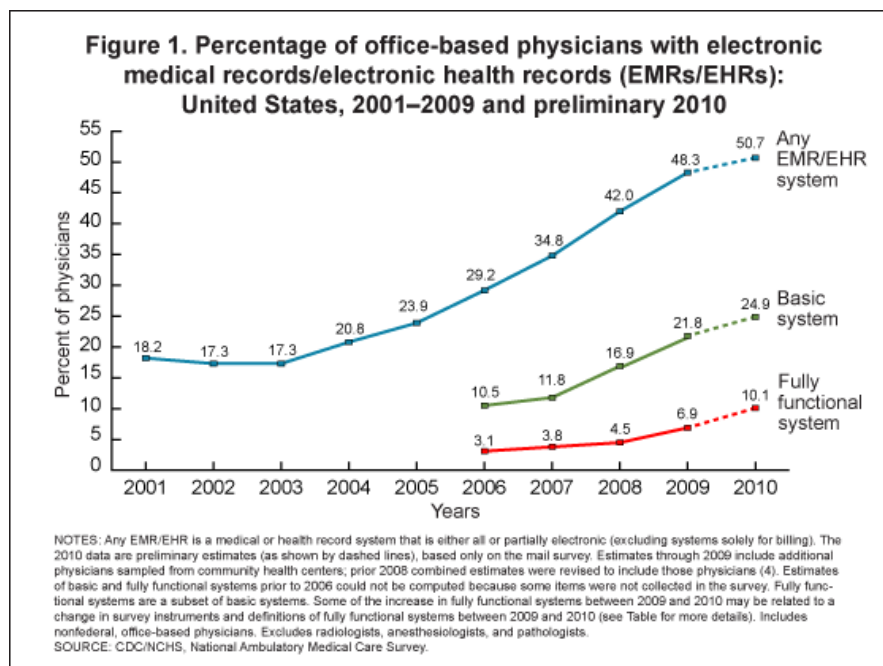

Expenditure Data, HHS and "Upgrade America's Health Care System: Pass Health IT Legislation Now," Business Roundtable, April 2, 2008). [http://www.benton.org/initiatives/broadband\\_benefits/action\\_plan](http://www.benton.org/initiatives/broadband_benefits/action_plan).

<sup>149</sup> Smaltz, Detlev and Eta Berner. "The Executive's Guide to Electronic Health Records." (2007, Health Administration Press), at 3.

<sup>150</sup> CDC, Chun-Ju Hsiao, *et al.*, Dec. 2010, NCHS Health E-State: Electronic Medical Record/Electronic Health Record Systems of Office-based Physicians: United States, 2009 and Preliminary 2010 State Estimates, at 1 ([http://www.cdc.gov/nchs/data/hestat/emr\\_ehr\\_09/emr\\_ehr\\_09.pdf](http://www.cdc.gov/nchs/data/hestat/emr_ehr_09/emr_ehr_09.pdf))

<sup>151</sup> U.S. Department of Health and Human Services Centers for Medicare & Medicaid Services 42 CFR Parts 412, 413, 422 et al. Medicare and Medicaid Programs; Electronic Health Record Incentive Program; Final Rule

<sup>152</sup> Figure from: CDC, Chun-Ju Hsiao, *et al.*, Dec. 2010, NCHS Health E-State: Electronic Medical Record/Electronic Health Record Systems of Office-based Physicians: United States, 2009 and Preliminary 2010 State Estimates. [http://www.cdc.gov/nchs/data/hestat/emr\\_ehr\\_09/emr\\_ehr\\_09.pdf](http://www.cdc.gov/nchs/data/hestat/emr_ehr_09/emr_ehr_09.pdf).

A robust, high-speed network is required to realize many of these benefits. Some telehealth activities are “asynchronous” and can be realized without real-time services. These include a variety of “store and forward” activities—including medical monitoring, e-mailing between patients and providers, and sharing of medical images. Other activities require real-time or “synchronous” communications. These include physician office visits conducted via videoconference, specialist visits that require high-definition video (e.g., dermatologist), and real-time medical imaging in time-sensitive cases. The latter category are significantly more bandwidth-intensive.

Even store-and-forward telehealth applications, such as sharing medical images with medical providers, can impose significant bandwidth demands. Medical images—such as X-rays—often are digitally stored in huge files (an MRI scan may consume many gigabytes of data, and files up to a terabyte have been seen with some medical studies). Uploading such files can be “quite bandwidth-intensive.” A provider may use a local digital medical-imaging device (like a CT scanner, or a digital X-ray machine in an orthopedist’s office, or an ultrasound device in an obstetrician’s office) to create files and upload them to a web-hosting store so that medical providers elsewhere can view and assess them. Medical centers may also wish to retain their own digital images, and simply allow viewer access by external electronic health records through a local linkage.<sup>153</sup> Bandwidth requirements will vary dependent upon the preferred practice and a network must be robust enough to accommodate different applications by thousands of medical professionals.

Sujansky and Associates explore the range of bandwidth needs in their assessment of the California Telehealth Network. (See Table 10, below.) Bandwidth requirements for video conferencing vary dependent on screen resolution. While standard-definition video conferencing can operate at 300 Kbps, high-definition video conferencing requires at least 1 Mbps. Store-and-forward operations also requires a range of bandwidth. While single image can be transferred at 500 Kbps, significantly more bandwidth (e.g., 10 Mbps) is needed to transfer large files. Absent adequate bandwidth, such transfers must be scheduled for low-usage times, such as overnight.

Other telehealth applications (e.g., audio-conferencing, clinical messaging and telemetry) do not necessarily demand a lot of bandwidth, though requirements will increase to accommodate growing numbers of telehealth users. Real-time telehealth applications, such as video- and audio-conferencing, may require greater network capacity because they are particularly sensitive to latency (delay in delivery of data packets), jitter (variations in

---

<sup>153</sup> Robert Rowley, June 3, 2010, EHR Bloggers, “Internet Connectivity and the Future of EMRs” (<http://www.practicefusion.com/ehrbloggers/2010/06/internet-connectivity-and-future-of.html>).

latency over time) and packet-loss. For instance, a typical conversation cannot be transmitted with latencies greater than 300 milliseconds. Greater delays would “disrupt natural verbal and visual communication patterns.” Conferencing applications also require stable rates of latency. Data buffers cannot function with excessive jitter, which compromises the quality of a video or audio-feed. High levels of packet loss or packets arriving out of order can also cause visible disruptions in an audio or video feed. Store-and-forward telehealth applications, in contrast, are not sensitive to latency, packet loss or jitter, reducing network requirements for these uses.

Emergency telehealth applications (e.g., remote video conferencing during crises) are extremely sensitive to network downtimes. Such emergency applications cannot be scheduled around network availability. Consequently, the network must be designed to accommodate the greatest level of potential use. Continuous telemetry of critically ill patients likewise demands a reliable network.<sup>154</sup>

Globally, networks have been developed to accommodate an array of telehealth applications. For example, the Virtual Critical Care Unit in Australia allows for telepresence support in the emergency, high dependency and obstetric departments between two distant Australian hospitals. To function, the network requires a 100 Mbps connection at each site. A telesurgical system in Korea likewise requires a 100 Mbps connection to facilitate data transport between sites. A Canadian telehealth study found that telesurgery is impractical with bandwidth below 4 Mbps, though it can be performed at 6 Mbps.<sup>155</sup> Of course, such applications are overlaid atop a network with a wide array of other uses, which demand additional bandwidth.

---

<sup>154</sup> Sujansky & Associates, LLC, Applicability of the California Telehealth Network as the Network Infrastructure for Statewide Health Information Exchange: An Assessment of the Optimal Roles for the CTN in California’s HIE, Oct. 8, 2009.

[http://www.sujansky.com/docs/CTN\\_for\\_HIE\\_Assessment\\_SujanskyAndAssociates\\_2009-10-08\\_FINAL.pdf](http://www.sujansky.com/docs/CTN_for_HIE_Assessment_SujanskyAndAssociates_2009-10-08_FINAL.pdf).

<sup>155</sup> R. Steele and A. Lo, “Telehealth and Ubiquitous Computing for Bandwidth-constrained Rural and Remote Areas”, *Personal and Ubiquitous Computing*, doi:10.1007/s00779-012-0506-5, 2012.

**Table 10: Network Characteristics of Telehealth Applications<sup>156</sup>**

<b>Category</b>	<b>Application</b>	<b>Acceptable Latency Level</b>	<b>Acceptable Packet Loss</b>	<b>Downtime Sensitivity</b>	<b>Minimum Bandwidth</b>
Conferencing	High definition video-conferencing	Low (<150 ms). Can not tolerate any recognizable delay.	Minimal. Recognizable gaps in video and audio feed are unacceptable.	Medium. Typically, tele-consultations do not involve emergency care, thus some downtime can be tolerated	1 Mbps (symmetrical) for single video channel; 2 Mbps (symmetrical) for two video channels)
Conferencing	Standard definition video-conferencing	Low (<150 ms). Can not tolerate any recognizable delay.	Minimal. Recognizable gaps in video and audio feed are unacceptable.	Medium. Typically, tele-consultations do not involve emergency care, thus some downtime can be tolerated	300 Kbps (symmetrical) for single video channel; 600 Kbps (symmetrical) for two video channels
Conferencing	Audio conferencing	Low (<150 ms). Can not tolerate any recognizable delay.	Minimal. Recognizable gaps in video and audio feed are unacceptable.	Medium. Typically, tele-consultations do not involve emergency care, thus some downtime can be tolerated	18 Kbps
Store-and-Forward	e.g., diabetic retinal examination, diagnostic image review, etc.	High.	High. Lost packets can be resent.	Low	.5 Mbps (except for full radiological studies, which require high bandwidths, e.g., > 10 Mbps

<sup>156</sup> Sujansky & Associates, at 11.

Category	Application	Acceptable Latency Level	Acceptable Packet Loss	Downtime Sensitivity	Minimum Bandwidth
Telemetry	Continuous telemetry (e.g., ECG, ICU monitors)	High. Reviewing providers does not need to get data at exact moment of recording (i.e., 1-5-second delay acceptable).	Medium. Lost packets can be resent. Applications can utilize buffers to handle packet loss.	High. Important clinical events can be missed if the network is down even temporarily.	.5 Mbps (possibly less, depending on number of data channels required)
Telemetry	Periodic telemetry (e.g., BP, blood glucose)	High.	High. Lost packets can be resent.	Medium. Data may be resent after network is back up	56 Kbps per data channel
Clinical Messaging	I.e., provider-patient exchange of email, instant messages, text messages, etc.	High.	High. Lost packets can be resent.	Medium. Data may be resent after network is back up	56 Kbps
Education/ Research	E.g., continuing medical education, grand rounds, population health research, etc.	High.	High. Lost packets can be resent.	Low	Asynchronous activities require .5 Mbps, synchronous require 1 Mbps



#### 4.5 THE RESIDENTIAL MARKET INCREASINGLY REQUIRES HIGH CAPACITY

The range and breadth of existing and potential consumer fiber applications is staggering. The emergence of a significant FTTP test-bed in the forms of the Google and municipal FTTP networks will accelerate the development of these applications, but even before the development of a widespread gigabit market in the United States, preliminary data regarding the impact of high-bandwidth networking is already evident.

For example, dependable, high-speed Internet access greatly improves the ability to work from home, or telework. This is often touted as the “most transformative”<sup>157</sup> and “biggest environmental benefit”<sup>158</sup> of FTTP. Indeed, telework confers a wide array of primary and secondary emissions benefits, which could provide significant cost savings to the City and its residents by reducing vehicle-operating expenses, the amount of time spent traveling, road repairs, and traffic congestion. In addition, by decreasing miles driven and gasoline burned, telecommuting benefits the environment and reduces greenhouse gases (GHG) by lowering auto emissions. Where telework occurs full time, it can reduce construction demand for office space and related electricity use.<sup>159</sup> Indeed, the American Consumer Institute estimates that simply doubling the number of full-time teleworkers (to 20 percent) could reduce national GHG emissions almost 600 million tons over the next 10 years due to reduced auto use, business energy conservation, and reduced office construction.<sup>160</sup>

“Universal, affordable, and robust broadband” is a “necessary prerequisite” for telework.<sup>161</sup> In market research conducted by CTC in 2008 in San Francisco, for example, 67 percent of respondents reported that they needed higher speeds than cable modem to telework and 70 percent of respondents indicated that they would telework more if there were sufficient

---

<sup>157</sup> Stephen Ezell *et al.*, “The Need for Speed: The Importance of Next Generation Broadband Networks,” Information Technology and Innovation Foundation, March 2009.15.  
<http://www.itif.org/files/2009-needforspeed.pdf>.

<sup>158</sup> Steven S. Ross and Masha Zager, “Fiber to the Home Is Green Technology,” *Broadband Properties*, Jan/ Feb 2009, at 30 [http://www.bbbmag.com/2009issues/jan09/BBP\\_JanFeb09\\_CoverStory.pdf](http://www.bbbmag.com/2009issues/jan09/BBP_JanFeb09_CoverStory.pdf).

<sup>159</sup> “Broadband Services: Economic and Environmental Benefits.” 20. (Reporting a \$25 million reduction in national real estate costs).

<sup>160</sup> *Ibid.*, 25-26. See also Jonathan Rintel, “An Action Plan for America: Using Technology and Innovation to Address Our Nation’s Critical Challenges,” The Benton Foundation, 2008. 24.  
[http://www.benton.org/initiatives/broadband\\_benefits/action\\_plan](http://www.benton.org/initiatives/broadband_benefits/action_plan); Consumer Electronics Association, “The Energy and Greenhouse Gas Emissions Impact of Telecommuting and e-Commerce,” July 2007/ 8, 29.  
[http://www.ce.org/Energy\\_and\\_Greenhouse\\_Gas\\_Emissions\\_Impact\\_CEA\\_July\\_2007.pdf](http://www.ce.org/Energy_and_Greenhouse_Gas_Emissions_Impact_CEA_July_2007.pdf). (Reporting average daily energy savings from telework of 16-23 kWh/ teleworker, assuming a “typical” vehicle with 21 miles per gallon and a 24 mile round-trip commute).

<sup>161</sup> Jonathan Rintel, “An Action Plan for America: Using Technology and Innovation to Address Our Nation’s Critical Challenges,” The Benton Foundation, Nov 2008. 24.  
[http://www.benton.org/initiatives/broadband\\_benefits/action\\_plan](http://www.benton.org/initiatives/broadband_benefits/action_plan).

speed.<sup>162</sup> Other studies support this finding. Indeed, fiber networks have quadrupled the amount of time employees spend working from their homes.<sup>163</sup>

Another significant, emerging application for high bandwidth broadband is the area of “aging in place” and other means of using technology to support seniors in their homes. In 2005, 12 percent (35 million) of the U.S. population was over 65. By 2030, that number will rise to 21 percent (71 million).<sup>164</sup> This growing demographic also represents a rapidly growing segment of the broadband market. In fact, the Pew Internet and American Life Project reports that the largest increase in Internet use since 2005 occurred in the 70 to 75 year-old age group, with online use for this age group increasing from 26 percent in 2005 to 45 percent in 2009.<sup>165</sup> Broadband use has increased by about half for Americans ages 12 to 24, roughly doubled for 25 to 64 year-olds, and more than tripled for seniors 65 and older. Notwithstanding this dramatic increase, broadband use by seniors 76 and older remains relatively low, at only 16 percent.<sup>166</sup> By contrast, 61 percent of those aged 50 to 64 have broadband at home.<sup>167</sup> Broadband use will undoubtedly continue to rise as younger users age. This provides a tremendous opportunity for extending the benefits of broadband access.

Broadband promises a range of applications that can benefit an aging population. In particular, broadband access can lower medical costs and prevent hospitalization through home-based monitoring; extend employment opportunities through telework; and foster ongoing relationships by allowing homebound seniors to connect to the outside world.<sup>168</sup> These benefits translate to dramatic savings in Medicaid and Medicare expenses for the federal and state governments, reduced demand for limited space in hospitals and long-term care facilities, and increased income and savings for residents. Because 60

---

<sup>162</sup> At the time the cable modem service deployed in San Francisco was state of the art and comparable to the speeds offered in Lawrence at that time, but still insufficient for very high end telework applications such as telepresence or advanced videoconferencing.

<sup>163</sup> “The Need for Speed: The Importance of Next Generation Broadband Networks.” *See also* Irene Berlinsky, “Working at Play, Playing at Work: The Rise of the Prosumer,” IDCLink, January 15, 2009.

<sup>164</sup> Robert Litan, “Great Expectations: Potential Economic Benefits to the Nation From Accelerated Broadband Deployment to Older Americans and Americans with Disabilities,” New Millennium Research Council, Dec. 2005. 6. [http://newmillenniumresearch.org/archive/Litan\\_FINAL\\_120805.pdf](http://newmillenniumresearch.org/archive/Litan_FINAL_120805.pdf)

<sup>165</sup> Sydney Jones and Susannah Fox, “Generations Online in 2009,” PEW INTERNET PROJECT DATA MEMO, Jan 2009. 2. [http://www.pewinternet.org/~media/Files/Reports/2009/PIP\\_Generations\\_2009.pdf](http://www.pewinternet.org/~media/Files/Reports/2009/PIP_Generations_2009.pdf)

<sup>166</sup> Jones and Fox.

<sup>167</sup> John Horrigan, “Home Broadband Adoption 2009,” Pew Internet and American Life Project, June 2009. <http://www.pewinternet.org/Reports/2009/10-Home-Broadband-Adoption-2009.aspx>.

(The chart at p. 13 illustrates use among all age groups.)

<sup>168</sup> Richard Adler, “Older Americans, Broadband and the Future of the Net,” Senior Net, 2006. <http://www.seniornet.org/research/SeniorNetNNApaper060606.pdf>

percent of U.S. healthcare spending is on seniors,<sup>169</sup> initiatives that target this population translate to significant government savings. In fact, considering only three categories of benefits (lower medical costs, lower costs of institutionalized living, and additional output generated by more seniors and individuals with disabilities in the labor force), economist Robert Litan identified up to \$927 billion in cost savings and output benefits from “business as usual” broadband deployment and an additional \$532 billion to \$847 billion in economic benefits from accelerated broadband deployment.<sup>170</sup> Even the low end of this estimate is equal to half of what the United States currently spends annually for medical care for all its citizens (\$1.8 trillion).

Broadband access allows seniors to search for medical information online. Approximately 20,000 medical websites exist for online research,<sup>171</sup> with a substantial subset targeted toward senior users. For instance, both the Mayo Clinic and the National Institutes of Health (NIH) have Web pages dedicated to senior health information. Similarly, AARP recently launched a series of online tools designed to help seniors select a physician or hospital and understand and diagnose their symptoms.<sup>172</sup> Seniors are already taking advantage of these services. Pew estimates that 70 percent of online adults (ages 64 to 72) and 81 percent of those aged 55 to 63 have used the Internet to find medical information.<sup>173</sup> Seniors are more likely to seek information online if they have a dependable, high-speed broadband connection. Such access empowers seniors by allowing them “to be preemptive and interactive in their efforts to combat the harmful effects of aging.”<sup>174</sup> It also translates to reduced medical expenses. In fact, as noted previously, Kaiser Permanente found that allowing enrollees (of all ages) to e-mail questions to their doctor through a secure messaging system led to a 7 percent to 10 percent reduction in primary care visits.<sup>175</sup>

Broadband also reduces medical costs for seniors by facilitating remote monitoring. Through the use of remote monitoring devices like ECG electrodes or blood glucose

---

<sup>169</sup> Charles Davidson and Michael Santorelli, “The Impact of Broadband on Senior Citizens,” U.S. Chamber of Commerce, Dec 2008. 22-23 <http://www.uschamber.com/assets/env/broadbandseniors.pdf>.

<sup>170</sup> Davidson and Santorelli, 18. Additional savings may be possible because broadband can help homebound residents comparison shop for best prices. For instance, a New York-based program helped lower-income seniors save \$19,000 on their drug costs alone.

<sup>171</sup> Herrick. 14.

<sup>172</sup> Davidson and Santorelli. 21-22. (Citing [www.mayoclinic.com/health/seniorhealth/HA99999](http://www.mayoclinic.com/health/seniorhealth/HA99999), <http://nihseniorhealth.gov/>, and News Release, “AARP Launches Four Online Health Tools to Empower Consumers To Make Informed Choices in Care,” AARP, Aug 22, 2008. [http://www.aarp.org/research/presscenter/presscurrentnews/aarp\\_launches\\_four\\_online\\_health\\_tools\\_to\\_empower.html](http://www.aarp.org/research/presscenter/presscurrentnews/aarp_launches_four_online_health_tools_to_empower.html)).

<sup>173</sup> Jones and Fox.

<sup>174</sup> Davidson and Santorelli. 21.

<sup>175</sup> Herrick. 14.

sensors, healthcare providers can continuously observe cardiac performance, food intake, and glucose levels, without requiring costly medical examinations or hospitalization. One study reports that 3.4 million seniors will be using such devices by 2012.<sup>176</sup> Remote monitoring is particularly useful for chronic diseases (such as coronary heart disease, chronic obstructive pulmonary disease, mental health disorders, diabetes, hypertension, and asthma), which require continued medical care and coordinated treatment among physicians. Chronic illness is prevalent among seniors. In fact, 45 percent of Medicare beneficiaries nationwide suffer from at least one chronic condition, representing nearly 80 percent of national healthcare spending—more than \$1 trillion each year.<sup>177</sup> Economist Robert Litan estimates that remote monitoring could cut Medicare expenses for the chronically ill by 30 percent, or \$350 billion each year.<sup>178</sup> As indicated previously, data from the Veterans Administration supports this estimate. The VA has cut hospital admissions by up to 60 percent for participants in its remote monitoring program, which relies on a network of “care managers” who track patient data online and contact participants if records indicate a need for immediate medical attention.<sup>179</sup>

Medical monitoring enabled by broadband may also delay and potentially eliminate the need for institutionalized living, with dramatic savings. As of 2002, five percent of Medicare-eligible seniors (1.6 million) lived in nursing homes.<sup>180</sup> This number is expected to increase as baby boomers retire and life-span increases. In fact, 44 percent of seniors will live in nursing homes at some point during their lifetime.<sup>181</sup> This care comes at a significant cost. In 2004, the federal government spent \$135 billion on long-term care for the elderly.<sup>182</sup> Nationally, the annual cost is nearly \$78,000 for a private room in a nursing home.<sup>183</sup>

Internet applications that are designed to “sharpen brain function” could lead to even greater potential savings. (At a minimum, these applications can help reduce isolation and

---

<sup>176</sup> Davidson and Santorelli. 23. (“Senior Citizens to See High Tech Sensors in Homes, on Bodies to Monitor Health,” Dec. 6, 2007, Senior Journal.

<http://www.seniorjournal.com/NEWS/Features/2007/7-12-06-SenCit2See.htm>.)

<sup>177</sup> Litan, 16.

<sup>178</sup> Litan, 16-17.

<sup>179</sup> Neal Neuberger, “Advancing Healthcare Through Broadband: Opening Up a World of Possibilities,” Internet Innovation Alliance, 2007. Date of Access: July 28, 2009.

<http://internetinnovation.org/factbook/entry/small-pilot-projects/>.

<sup>180</sup> Litan, 21.

<sup>181</sup> Litan, 21. *See also* Davidson and Santorelli. 22-23. (Projecting 69 percent of seniors will need eventual long-term care.)

<sup>182</sup> Litan. 21. This includes \$92 billion (68 percent) for nursing home care and \$43 billion (32 percent) on home care.

<sup>183</sup> Litan, 21.

depression among seniors.<sup>184</sup>) Neurologists have reported that mental exercises, like puzzles, logic games, and reading material available for free through the Internet, can reduce an individual's chance of developing Alzheimer's disease by 70 percent.<sup>185</sup> Accessing such sources of "mental exercise" online also means that elderly people with limited mobility are not dependent on driving to a store or library to get what they need. According to one analysis, "interventions that could delay the onset of Alzheimer's disease by as little as one year would reduce prevalence of the disease by 12 million fewer cases in 2050."<sup>186</sup> Because Alzheimer's and dementia currently cost the United States more than \$148 billion annually in Medicaid and Medicare services,<sup>187</sup> the potential savings are significant. In addition to these economic benefits, such applications will help allay the concerns of nearly 60 percent of seniors who worry about "staying 'mentally sharp.'"<sup>188</sup>

On average in the United States, a private room in a nursing home costs \$168 per day.<sup>189</sup> The average time a senior citizen will live in a nursing home is projected to be two and a half years.<sup>190</sup> If at-home broadband-enabled health monitoring were able to reduce the average resident's length of stay in a nursing home by six months, the Lawrence community would see dramatic reductions in nursing home fees.

The savings in nursing home expenses would be offset by the cost of additional at-home health care, but those fees are a small fraction of the daily cost of nursing home care. Private at-home care averages \$19.23 per hour nationally.<sup>191</sup> With broadband in the homes of patients, medical monitoring could make it possible to need as little as one hour every day of in-home care.

In fact, according to AARP, Medicaid funding can support an average of three people in home and community-based settings for the same cost as supporting one person in a

---

<sup>184</sup> Davidson and Santorelli. 15. The same Internet applications can help improve quality of life for seniors who often complain of isolation and experience depression. In fact, studies have found that "seniors who master computer skills appear to have fewer depressive symptoms."

<sup>185</sup> "Four Pillars of Alzheimer's Prevention: Exercise Physical, Mental and Mind/Body," Alzheimer's Research and Prevention Foundation. [http://www.alzheimersprevention.org/pillar\\_3.htm](http://www.alzheimersprevention.org/pillar_3.htm).

<sup>186</sup> Davidson and Santorelli. 22.

<sup>187</sup> Davidson and Santorelli.

<sup>188</sup> Davidson and Santorelli, 12.

<sup>189</sup> Debra Caruso and Christina Tso, "LTC Cost by City," Business Wire. <http://www.assn-insurance.com/pdf/LTCCostByCity.PDF>.

<sup>190</sup> Caruso and Tso.

<sup>191</sup> Caruso and Tso.

nursing home.<sup>192</sup> Litan's estimates are consistent with these figures, finding that the difference between institutionalized and home care is at least \$50,000 per person.<sup>193</sup>

Litan further assumes that home-based monitoring will prevent institutionalization for 1 percent of seniors in 2010, rising to 2 percent to 3 percent by 2030, for an estimated cumulative savings of nearly \$1 billion in 2010 and \$17 to \$32 billion in 2030.<sup>194</sup> This approach represents an improvement in the quality of life for seniors in addition to the obvious economic benefits of home-based care. Indeed, an AARP study found that 87 percent of seniors would prefer to have help provided to them in their homes rather than in an institution.<sup>195</sup>

In terms of Alzheimer's, while broadband-assisted reduction in deaths caused by the disease is speculative, broadband could postpone or potentially reduce the incidence of the disease. And to the extent that broadband access does postpone the incidence of Alzheimer's, those residents who are spared will save on medical expenses: On average, individuals affected by Alzheimer's disease are paying three times as much in health care costs as those who do not have Alzheimer's or dementia.<sup>196</sup>

---

<sup>192</sup> Ari Houser, Wendy Fox-Frage, and Mary Jo Gibson, "Across the States: Profiles of Long-Term Care and Independent Living," AARP, 2009. [http://assets.aarp.org/rgcenter/il/d19105\\_2008\\_ats.pdf](http://assets.aarp.org/rgcenter/il/d19105_2008_ats.pdf).

<sup>193</sup> Litan, 21. (Reporting a price differential of \$48,000 to \$64,000, depending upon whether the individual is placed in a private or semi-private room).

<sup>194</sup> Litan, 23.

<sup>195</sup> Davidson and Santorelli, 25.

<sup>196</sup> Alzheimer's Facts and Figures, Alzheimer's Association.

[http://www.alz.org/alzheimers\\_disease\\_facts\\_figures.asp?gclid=CjG-K0705sCFRd75Qodi28qjQ](http://www.alz.org/alzheimers_disease_facts_figures.asp?gclid=CjG-K0705sCFRd75Qodi28qjQ).

## 5. POTENTIAL STRATEGY 1: CONTINUE AND ENHANCE CURRENT CITY FIBER AND CONDUIT PROJECTS

We recommend pursuing and expanding the full range of contemplated fiber and conduit construction projects that is currently in development by City staff. The projects, which are discussed in more detail below, represent cost-effective, efficient, and low-risk infrastructure initiatives that would be mutually beneficial for the City and its partners such as KU and the County.

We also recommend that the City expand and enhance the current strategy to promote further infrastructure development and expansion.

### 5.1 BACKGROUND REGARDING EXISTING CITY CONDUIT AND FIBER PROJECTS

The City has completed an impressive roster of fiber infrastructure projects over more than 15 years, from the fiber backbone installed in City Hall in 1997 to a number of outside plant fiber extensions this year and the new partnership with the University to share costs with respect to some new fiber and conduit deployment.<sup>197</sup>

Looking to the future, the City is contemplating a number of important projects that the IT Department has researched and developed, including additional projects with KU and the County, and potential fiber partnerships with community anchor institutions (CAI) such as Lawrence Memorial Hospital, Lawrence Public Library, and Lawrence Public Schools.<sup>198</sup>

### 5.2 BACKGROUND ON MUNICIPAL FIBER NETWORKS FOR INTERNAL USE

Lawrence's efforts to build fiber and conduit to meet public sector networking needs are part of a broader trend among local governments. Indeed, localities have exercised significant leadership in broadband innovation in the United States. For more than 15 years, a significant minority of localities have chosen to build or purchase fiber for themselves.<sup>199</sup>

---

<sup>197</sup> These projects are documented in the "Fiber Projects Overview" report prepared by Mr. James Wisdom, Director of the City's Information Technology Department, and dated March 2013.

<sup>198</sup> See, James Wisdom, "Fiber Projects Overview," March 2013.

<sup>199</sup> These internally-focused projects contrast to those that are public-facing: networks built by public entities for the purpose of serving residential and business consumers where the private market has failed to deliver adequate service or has failed to deliver competition

In this model, the locality negotiates, purchases, or constructs fiber optics to serve its own needs and those of its local community anchor institutions (CAIs)—connecting over fiber entities such as schools, libraries, public safety departments, and government buildings, and perhaps senior centers, public housing projects, or healthcare institutions. This is the model Lawrence has used over the past years, on an incremental basis.

In recent years, Lawrence has gradually built a significant fiber base. The City is among many hundreds of communities that have used cautious fiber strategies, with a range of variations, including Albuquerque, San Antonio, New York City, Los Angeles, Seattle, San Francisco, Chicago, Washington, D.C., Boston, and hundreds of suburban and rural towns and counties.

We anticipate that this trend, which has continued unabated over the past decade and a half, is likely to continue into the future. The Broadband Technology Opportunities (BTOP) grant program under the federal Recovery Act has, in some parts of the country, accelerated this trend by enabling localities and regional consortia to build more fiber to public sector and other anchor institutions. And American communities are increasingly interested in this type of network to achieve self-reliance in communications.

### 5.3 TO EXPAND ITS FOOTPRINT, LAWRENCE SHOULD TAKE A COORDINATED APPROACH TO INSTALLING CONDUIT

To expand its existing fiber footprint, the City should place conduit during all capital improvement projects to dramatically lower the cost of network construction.<sup>200</sup> We recommend that the City install conduit any time a capital improvement project requires breaking ground in the public right-of-way. To maximize the benefit of this strategy, we would further recommend that the City be aware of opportunities to install or obtain fiber and conduit through activities in the rights-of-way and discover and pursue these opportunities by way of explicit, formal procedures.

We also recommend that the City adopt guidelines addressing conduit construction so that it can quickly work with a potential partner to add conduit to a project and integrate with existing City conduit. Standards should be prescriptive, but there should be sufficient flexibility to modify them if impractical or unsuitable in certain circumstances. These documents would serve as references in developing, for instance, site plan conditions for utility- or developer-provided infrastructure.

---

<sup>200</sup> See "Brief Engineering Assessment: Efficiencies available through simultaneous construction and co-location of communications conduit and fiber," White Paper, CTC, 2009.  
<http://www.ctcnet.us/CoordinatedConduitConstruction.pdf>



The City's pending Farmland project, for example, offers an important economic development opportunity in Lawrence. As the roads are developed, conduit could be installed and documented, enabling the City to place fiber when needed at very low cost relative to the cost of retrofitting those roads for fiber infrastructure. Ideally, the conduit would also extend to the East Hills Business Park and could connect, either now or in the future as the construction opportunity arises, to the City's existing fiber and conduit on the north and south sides of Highway 10. Conduit burial during construction could enable the City to lease fiber to private providers or deploy services itself, as the need arises. The incremental cost of the conduit during construction is negligible relative to the cost of building fiber later, after the development is complete.

We note that the City is already using this strategy under some circumstances and we commend the efforts taken to date in this regard. For example, the City has, for many years, expanded its network infrastructure by installing fiber or 1¼-inch conduit to support important internal needs, or in concert with a private partner. The IT Department also notes an upcoming opportunity to install conduit and fiber while the City's Public Works and Utilities departments replace infrastructure in the rights-of-way along 15<sup>th</sup> Street.<sup>201</sup>

The IT Department, City Engineer, Traffic Supervisor, and Public Works Department have demonstrated, through collaborative effort and cooperation, the potential to realize efficiencies by placing conduit during other projects. The City Engineer and IT Department have developed a well-functioning process to take advantage of capital improvement projects in the rights-of-way to place conduit, and the City Engineer tells us that their experience demonstrates that the incremental cost of this process is negligible relative to the broader cost of the CIP.<sup>202</sup>

To formalize and enhance the efforts made to date, we recommend that these strategies be considered by the City Commission and approved as a City-wide policy with appropriate funding.

Further, the City should be aware of opportunities to install or obtain fiber and conduit through activities in the rights-of-way and discover and pursue these opportunities by way of explicit, formal procedures. These opportunities may include grant-funded initiatives for particular departments; road construction; road widening; undergrounding of utilities; construction of new and existing utility infrastructure (electric, telephone, cable, water, sewer); and opportunities to negotiate for in-kind and reduced-cost benefits in franchise or rights-of way agreements, or in exchange for use of City infrastructure.

---

<sup>201</sup> Wisdom, p. 32.

<sup>202</sup> Interview with City Engineer David Cronin, March 20, 2013.

The City should have formal, structured internal mechanisms for a telecommunications planning entity to capture and review all initiatives relating to rights-of-way construction. The City should also include site plan conditions for new construction that provide the City with conduit in areas where utilities are newly buried, and provide entry and riser access in buildings where a City network may benefit the public.

The City should maintain contact with local telecommunications providers to be aware of their upcoming plans. Likewise, entities performing construction in the rights-of-way should provide sufficient information in the permitting process for the City to judge if a co-location opportunity is available, and provide sufficient time for the City to coordinate adding conduit and vaults as part of the construction.

The City should also be alert to the plans of service providers entering the area, and should set up capture points to find out about them, including requests for permitting antennas, permits for rights-of-way construction, discussions in trade or business journals, coordination with other governments in the region, and discussions with Douglas County and regional economic development entities.

The potential benefits of this coordinated approach to conduit and fiber installation would accrue not only to City agencies but also to private providers. A coordinated fiber network design can provide capacity for dozens of separate service providers. This strategy has the benefit of maximizing long-term value and minimizing the potential for future disruption.

One approach is to construct a high-capacity conduit bank connected to manholes at regular intervals according to a standardized design (Figure 14). The primary manholes in turn would connect to lower-capacity conduit connected to residential or business service drops or to wireless infrastructure. Small manholes or handholes can be managed by particular service providers for their proprietary access and service to particular customers.

Figure 14: Long-Term Conduit Installation Strategy

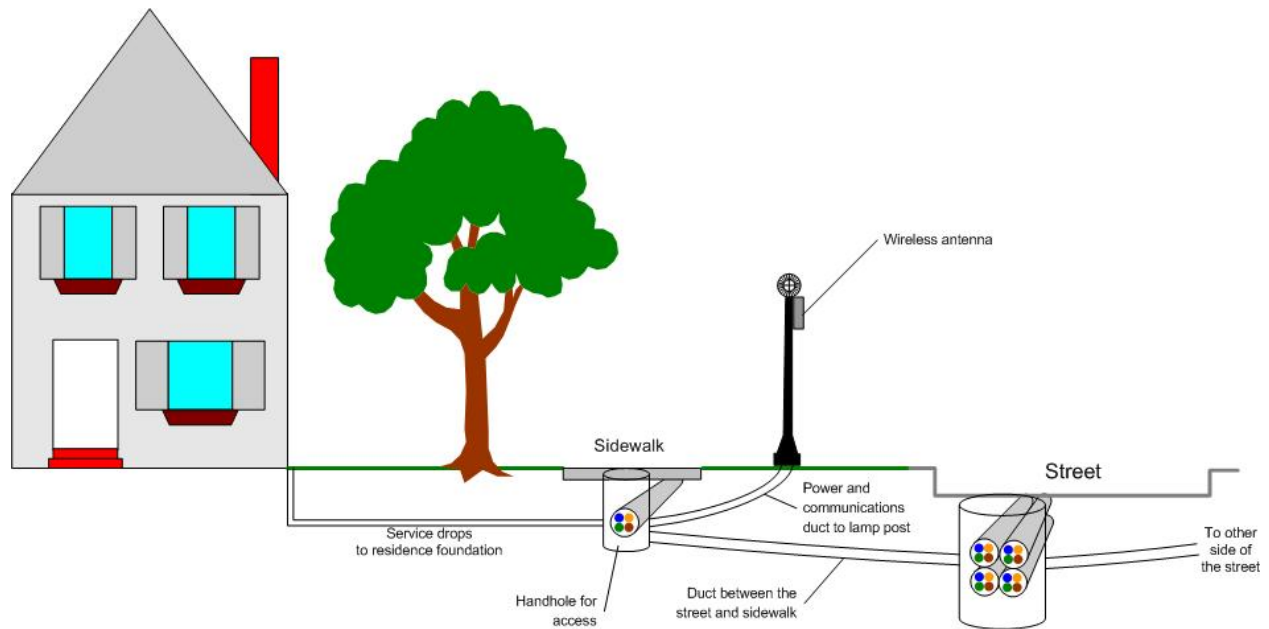

#### 5.4 TO MAKE ITS CONDUIT FUTURE-PROOF, LAWRENCE SHOULD USE A ROBUST SPECIFICATION WITH FLEXIBILITY TO ADD FIBER IN THE FUTURE

Ideally, the City should maintain a specification for conduit that is sufficient to meet future needs (i.e., a relatively large conduit that is able to hold more than one bundle). While the 1¼-inch conduit that the City has installed in the past may have been sufficient for meeting the City’s needs, installing larger conduit with multiple ducts and pull strings would create excess capacity that the City could tap to meet its future needs or those of its partners, or could lease to the private sector. (See Figure 15.) The IT Department notes the benefit of larger conduit in its overview report, as well: “Burying 3” conduit during projects would be preferred.”<sup>203</sup> Three-inch conduit can readily contain two or three innerduct, which each can carry a large-count fiber cable. Four-inch conduit can contain six innerduct.

<sup>203</sup> Wisdom, p. 32.

Figure 15: Illustration of Value Presented by Larger Conduit

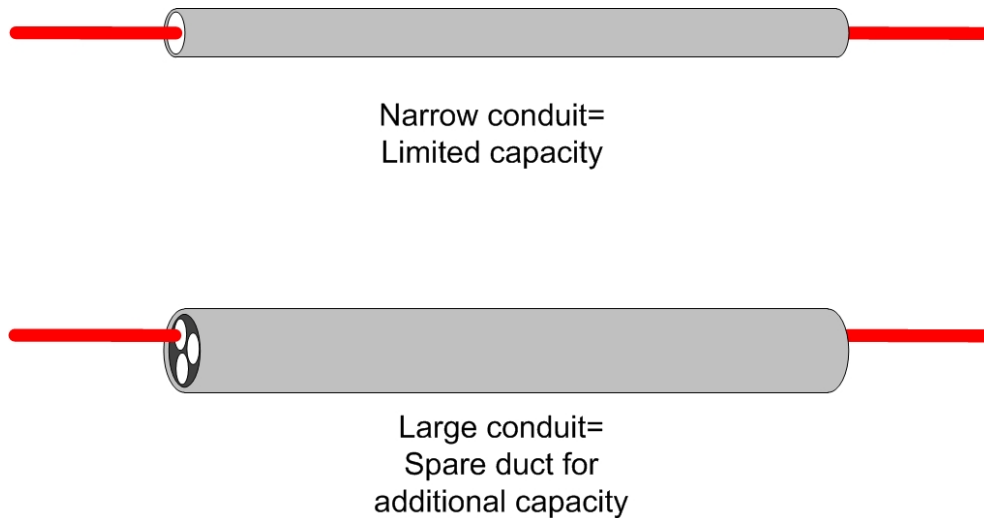

The cost of installing larger conduit will be higher (not so much because the conduit itself is more expensive, but because the larger conduit requires digging a larger trench). For this reason, we recommend that the City discuss significant conduit installation plans with potential partners such as Level 3 and the Kansas Fiber Network; the City may be able to negotiate a cost-sharing relationship if the conduit will offer access to key routes, and if it is large enough to hold multiple ducts that could be used by private sector providers as well as the City.

## 5.5 TO PREPARE FOR FUTURE FIBER-TO-THE-PREMISES, LAWRENCE CAN REQUIRE FIBER-READINESS IN GREENFIELD AND RECONSTRUCTION AREAS

The City should consider the potential to reduce the cost for future advanced broadband deployment by requiring some combination of cable pathways, fiber connections, and internal fiber wiring to be built by developers and owners during construction, reconstruction, and rehabilitation projects.

This initiative is worth considering because it represents a small burden for developers, and a potentially noteworthy incremental benefit to the City—especially if rehabilitation of existing residential units over time becomes an important phenomenon.

This model was pioneered in the United States by the city of Loma Linda, California, through its Connected Community Program (LLCCP). In conjunction with the city's development of a citywide fiber optic network, the city council added connectivity standards to the building code. "The City building code now requires all new commercial

and residential developments (or re-models involving greater than 50% of the structure) to equip the new structures with a fiber-optics interface and copper cabling throughout.”<sup>204</sup>

Loma Linda has received international recognition for its ordinance, which provides that “[i]n recognition of the need to provide local residents and businesses within the community with additional options to meet their telecommunications needs, as adopted by city council resolution, all new development projects within the city, regardless of whether such new development falls within the fiber-optic master plan area, and additions that exceed more than fifty percent of the original structure that fall within the fiber-optic master plan area, will be required to participate in, and will be bound by, the connected community program....” (Ord. 629 § 1, 2004).<sup>205</sup>

The city of Sandy, Oregon, which recently announced a public-private partnership for building fiber to the premises (FTTP), has also passed an ordinance requiring developers to put conduit all the way into a home, and to deed that conduit to the city. City Council Member Jeremy Pietzold noted recently that his only regret about the new conduit ordinance is that Sandy did not have the forethought to pass it 10 years ago—which would have better positioned the city and its private partner to build the FTTP network they currently plan.

A model such as that in Loma Linda or Sandy will have far greater impact in areas of new construction and in rapidly expanding cities (such as Sandy, which is the fastest growing city in Oregon, and is developing into previously uninhabited areas). In Lawrence, which is an established community with less growth, the results are likely to be far more modest.

---

<sup>204</sup> “The Loma Linda Connected Community Standard,”

<http://www.lomalinda-ca.gov/asp/Site/LLCCP/AboutLLCCP/TheLLCCPStandard/index.asp>

<sup>205</sup> The city also provides the following specifications for new construction:

1. Data cabinet in master bedroom
2. Cable bundle set—2 Cat 6, 1 coax in each living space, 2 sets in master bedroom and family room
3. Fiber into data cabinet and community MDF
4. Fiber throughout the development
5. Build a community MDF
6. Deed the infrastructure to the city once completed
7. City provides builders with design, SOW, and BOM
8. City provides list of certified and approved contractors
9. Cost to the builder is estimated at approximately \$3,500 per unit, assuming metro California labor costs

## 5.6 TO MAXIMIZE CITYWIDE OPPORTUNITIES FOR INTERCONNECTEDNESS, LAWRENCE SHOULD SECURE SPACE IN KU'S NETWORK OPERATIONS CENTER

The University of Kansas' (KU) network operations center (NOC) represents a significant opportunity for interconnection—both because of KU's central location within the City, and because the NOC already hosts virtually all of the communications service providers in the area. The City should work with KU to secure space in the NOC for a fiber cabinet; this would provide an opportunity for peering and interconnectivity among the full range of public sector entities within Lawrence, including City and County government, Lawrence Public Schools, Haskell Indian Nations University, and so on. We are optimistic that KU will agree to such an arrangement, given the university staff's extreme flexibility and openness to working with the City on connectivity-related projects.

## 5.7 TO MAXIMIZE ITS CONSTRUCTION RESOURCES, LAWRENCE SHOULD PRIORITIZE COST-EFFECTIVENESS, EFFICIENCY, AND ECONOMIC DEVELOPMENT IMPACT

With a range of potential opportunities for fiber and conduit installation in sight, one challenge will be prioritization of projects. We recommend that the City should act immediately to install conduit and fiber when cost-effective opportunities present themselves—such as during capital improvement projects and other disruptions to the rights-of-way. The City's roster of economic development projects also presents a guide to identifying future routes for expanding its infrastructure; where clear economic development projects are in sight but not yet concrete, the City should build where the opportunity arises, but with less urgency. These opportunities will evolve over time. In this way, the City can keep its spending on fiber and conduit projects modest and incremental, and maximize the benefits of existing capital improvement projects in the right-of-way.

## 5.8 TO CAPTURE INFRASTRUCTURE OPPORTUNITIES, LAWRENCE SHOULD ESTABLISH PUBLIC SECTOR WORKING GROUPS

The degree of success achieved in public sector fiber initiatives is frequently a function of the level of collaboration and cooperation among public sector entities. Accordingly, the City should establish public sector working groups to facilitate broadband collaboration and best practices. We have identified two impressive existing collaborative groups; we recommend institutionalizing and expanding both of them.

First, representatives of Lawrence's community anchor institutions (CAI)—including the City, County, Lawrence Memorial Hospital, Lawrence Public Library, and Lawrence Public

Schools public safety agencies, KU, and Haskell Indian Nations University—met during preparation of this report and very effectively shared experiences, tips, and frustrations. Notably, the group looked for ways to collaborate on overcoming some of the challenges that any community faces in terms of the cost and functionality of communications services. We recommend that the City facilitate periodic meetings of this group as an opportunity to share experiences, provide updates, and coordinate new initiatives.

Second, the IT and Public Works departments have very effectively coordinated their work over a number of years so as to take advantage of opportunities in the rights-of-way (see Section 5.4); we recommend formalizing a committee to oversee these kinds of projects and expanding its membership to include all relevant departments of City government and the City Manager's office, so that all opportunities for efficiency are realized. This type of collaboration and breaking down of silos will pay significant dividends over time, because no opportunity to cost-effectively install new infrastructure will go unexplored.

## 6. POTENTIAL STRATEGY 2: COMPLETE FIBER RINGS WHERE POSSIBLE DURING THE COURSE OF ROUTINE FIBER AND CONDUIT INSTALLATION

Lawrence should focus on expanding its existing fiber and conduit footprint in such a way as to connect existing fiber routes into rings.<sup>206</sup> Expanding to ring architecture would result in significant operational benefits in that it would offer a level of redundancy, reliability, and resilience that the current infrastructure does not have. These benefits would accrue for the City's internal communications services and would also make the City's fiber and conduit more marketable to private sector providers who seek to enter or expand service in Lawrence.

As an example, redundant fiber routes would allow the system to continue to operate at full functionality even in the event of a fiber cut (i.e., if a single fiber route is cut, the network is disabled—but if the fiber is in a ring, the network traffic can reverse course at the point a single route is cut, and go around the ring to reach its destination).

Connecting the City's fiber and conduit routes into rings would also increase the capacity of the links, making it possible to operate more advanced services in the future. And the change would also increase the value of the existing network with respect to potential leasing of the fiber.

Figure 16 below presents a high-level overview of a redundant fiber network. Figure 17 illustrates the single points of failure in a fiber route, and the multiple paths enabled by fiber rings connecting to the existing fiber.

Specifically, the City has identified locations where it can add to existing conduit to create a backbone ring. Figure 18 illustrates gaps totaling four miles. In our estimate, \$320,000 to \$650,000 would enable placement of conduit to complete the ring and form a 17-mile backbone ring.

---

<sup>206</sup> Wisdom, p. 14.



Figure 16: High-Level Diagram of Redundant Fiber Network

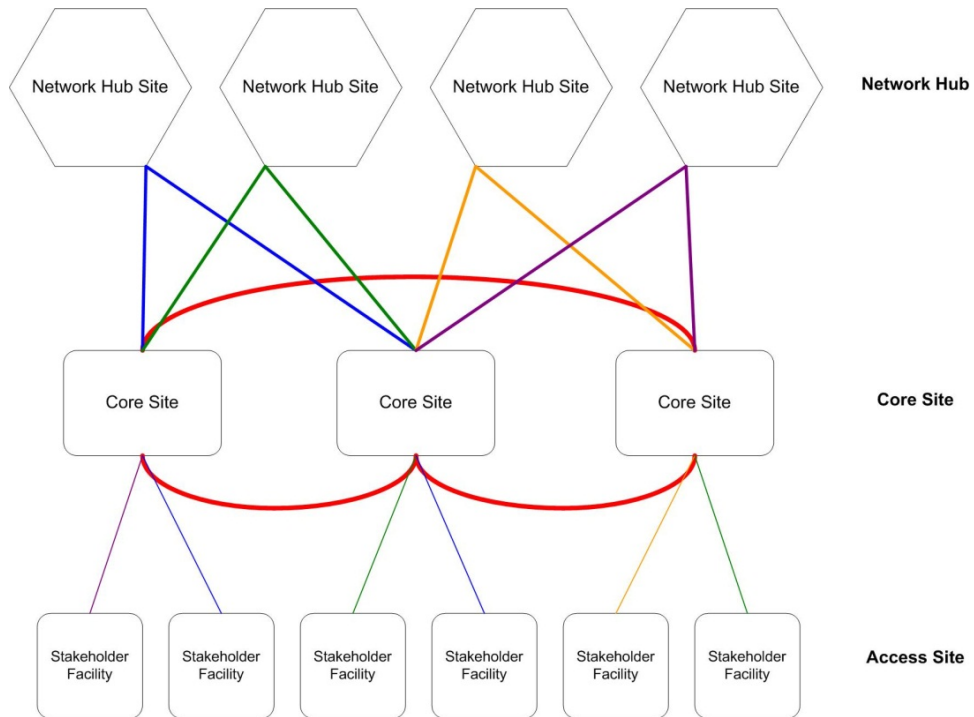

Figure 17: Multiple Survivable Paths from Redundant Fiber Connections

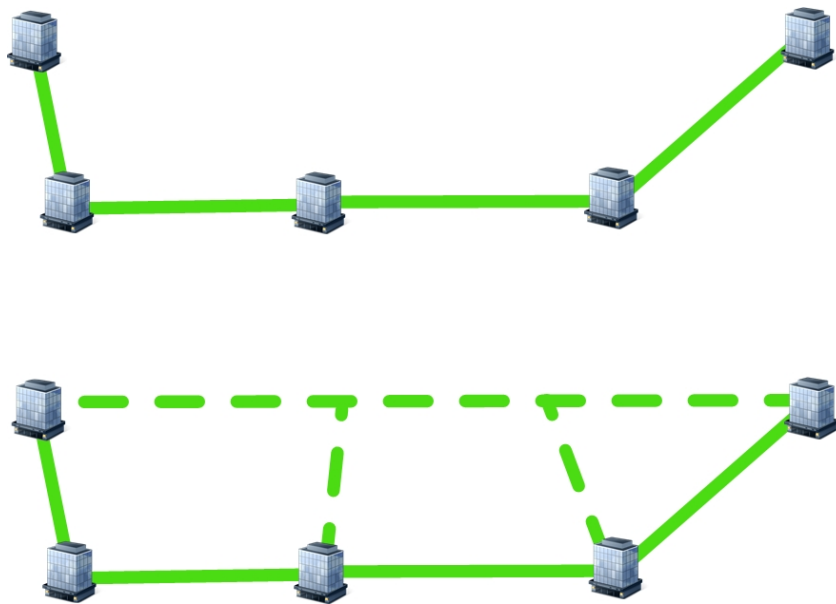
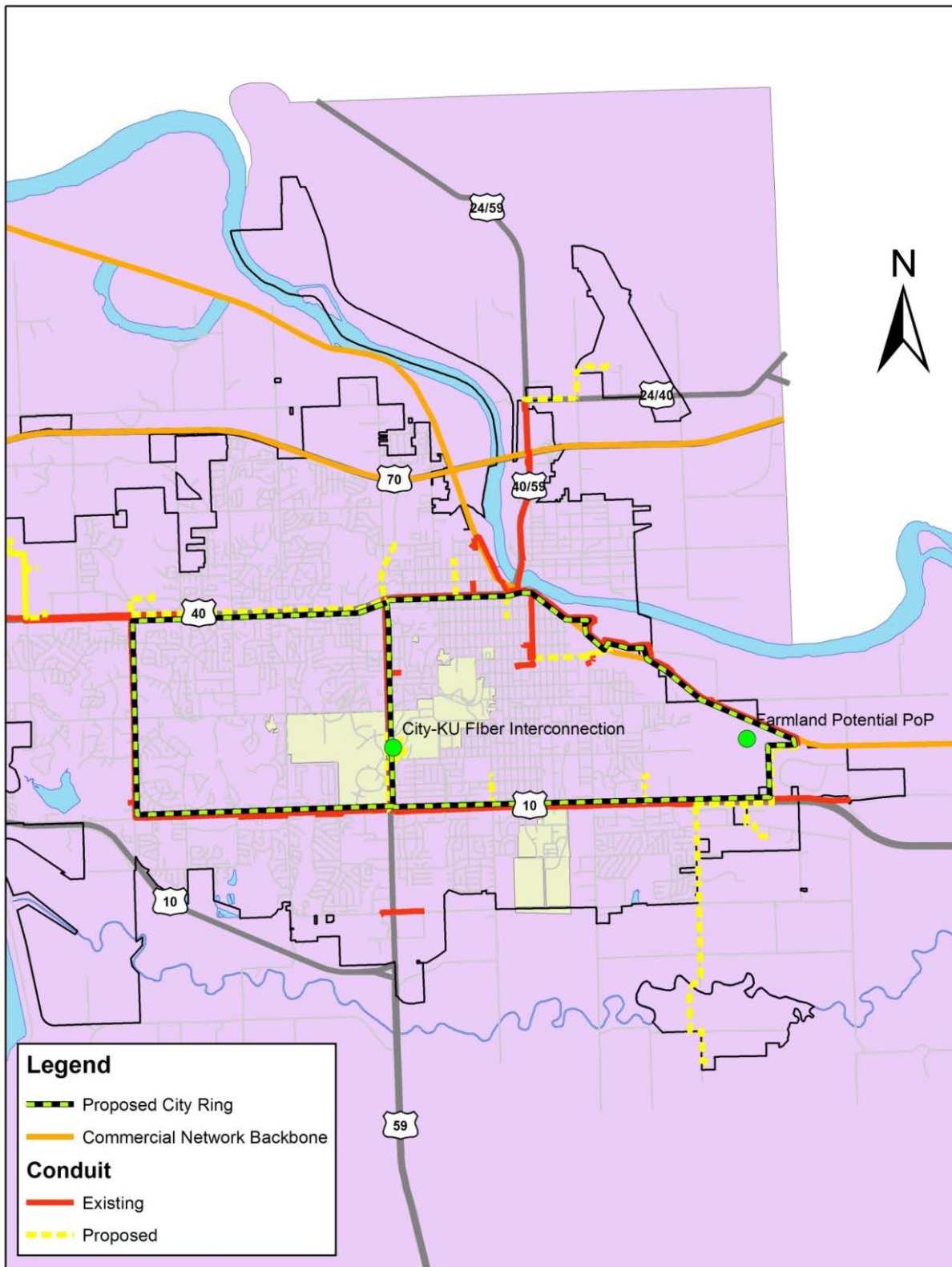

Figure 18: Map of Potential Fiber and Conduit Network Rings



The backbone ring would have several potential roles:

- Increasing the robustness and capacity of City communications
- Providing a robust backbone for other institutional users, such as KU, USD-497, Lawrence Public Library, Douglas County, the State, and Lawrence Memorial Hospital
- Creating dual routes from any location on or near the backbone to key IT and communications resources, such as a potential POP peering location in Farmland or connections to KanREN and other national backbone networks
- Developing a core route for future expansion, including leases to private sector networking companies or establishing a backbone for a citywide fiber-to-the-premises network

In order to construct the rings from the existing fiber, there are two additions necessary:

- Adding four miles of conduit to fill gaps (approximately 1.5 miles of gaps are identified in the City Fiber Projects Overview as a potential Douglas County Project), and
- Pulling fiber cable through the conduit (for 13 miles; four miles have existing fiber)

In our estimate the cost will range from \$320,000 to \$650,000. Assuming the pricing in the City's agreement with Verizon, the cost of labor and materials for 13 miles of 288-count fiber is \$234,529.

In order that the network be scalable for the potential roles above, we recommend a larger cable count. This is particularly important because 1) the existing Verizon and City conduit are only 1¼-inches in diameter and cannot be augmented by installing new cables after the cable is installed, and 2) the City has accounted for the majority of the 288-count cable with existing City and institutional applications and may not have capacity for future applications, such as FTTP or private sector lease. The fiber is a long-lived asset and will be costly to upgrade if the 288-count is not sufficient. Increasing the fiber count to 432 can likely be accomplished for an additional \$100,000 to \$200,000.

We note, too, that the ability of these fiber rings to support the City government's current and future application requirements supports a strong business case for this investment.

The City currently spends about \$50,000 per year on about a dozen and a half leased circuits to support its internal connectivity needs. The City incurs additional equipment

and installation expenses, as well. Replacing the leased circuits with connections over City-owned fiber would pay for itself in a relatively short period of time—especially given that the current cost of leased circuits will only increase as the private providers raise their prices, and the City’s communications needs demand higher capacity connections. (Indeed, at some point, adequate leased connections will become cost-prohibitive for the City.)

In addition to the cost savings, the fiber would replace T-1s and other less capable services that deliver, in some cases, only 1/600<sup>th</sup> of the connectivity that the new infrastructure would enable. The new infrastructure would enable the City to competitively procure commodity Internet bandwidth, and would enable the schools, libraries, and other public sector entities that contract independently for communications services to benefit from a truly competitive market enabled by City fiber.

## 7. POTENTIAL STRATEGY 3: LEASE ACCESS TO EXCESS CITY FIBER AND CONDUIT

We recommend the strategy of maximizing the City's existing fiber infrastructure by making it available, under defined terms, to the private sector to encourage competition, economic development, and last-mile construction (i.e., further connections from the City's backbone to homes and businesses).

### 7.1 BUSINESS MODEL BACKGROUND

A growing body of evidence suggests that localities can successfully implement this strategy given the proper market conditions. The Recovery Act grants made by the U.S. Department of Commerce actually require this strategy: Grant recipients must commit to nondiscriminatory, open access policies that make access available to third-party service providers.

The reasoning behind this approach is straightforward: By making middle-mile capacity available where it does not otherwise exist, and at very reasonable cost, a community reduces the barriers to investment for entrepreneurial companies (and non-profits) that want to build last-mile capacity. Those companies' lease arrangements would lead to not only revenues, but also stimulate private investment and the extension of broadband service to members of the community that otherwise would not have it, or would not have the benefits of competition.

Because many of the Recovery Act infrastructure grants incorporate this business model, significant data will emerge over the next few years as to the scope of the ROI of this model. Preliminary indications from many of these projects are very good. In both metropolitan and rural areas, grant recipients are engaged in negotiations with last mile providers who seek access to the new middle mile fiber that will make it possible for them to affordably reach areas for last mile service.

### 7.2 RECOMMENDED STRATEGY AND RISK ANALYSIS

We suggest that the City make available spare conduit and fiber capacity for use by the private sector at competitive rates.

Such an arrangement would ideally result not only in a modest revenue stream to the City, but would also enable competitive providers to compete more aggressively in the

Lawrence market, whether they are new entrants to the market or already established in Lawrence.

This strategy is also low risk for Lawrence. The ongoing efforts to expand Lawrence's fiber footprint are fully justified by the need to meet internal communications needs; it is an added economic bonus to open the fiber/conduit infrastructure to private companies.

The City has already undertaken this strategy through its partnership with Wicked Broadband, which leases some City fiber in order to serve customers within Lawrence. This example is an excellent illustration of how City fiber can enable a range of private sector companies and entrepreneurs to compete in the Lawrence market.

In the course of this project, CTC analysts spoke with a range of communications providers about their interest in using the City's fiber to extend their capacity to serve customers in Lawrence. Wicked Broadband expressed continuing interest. The Kansas Fiber Network, a collaborative initiative of most of the state's rural telephone companies, also expressed interest in the idea and in expanding beyond its current footprint in Lawrence (according to KFN officials, KFN already has more than five miles of fiber in Lawrence). In addition, planners for Level 3 signaled interest; Level 3 has a track record of taking advantage of such opportunities in other communities.

To enhance these opportunities, we recommend that the City consult with private sector providers when constructing or enhancing conduit or fiber routes. If a route is of interest to a provider, the cost of construction can be shared or offset by purchase or lease fees from a private sector provider, and the size and quantity of infrastructure can be adjusted to meet the provider's need.

The City may also wish to offer preferred pricing on conduit or fiber to providers that commit to building out unserved areas, low-income neighborhoods, economic development zones, or other high-priority areas.

The risk to the City is relatively low because if there are few or no takers, the cost is marginal—the cost only of planning and marketing efforts. And if there are takers, then the City is using its infrastructure to open up and enable a competitive market where none currently exists.

In order to determine and select the model that is most likely not only to give the City some modest revenues, but also to facilitate the City's public policy purposes (e.g., economic development, open and competitive markets, enabling new and better services), we recommend that the City undertake a request for information (RFI) process to identify potential private sector partners. The RFI should specify the amount and nature of the

asset available for lease (fiber and conduit) but offer the bidders flexibility to propose their own business and compensation models for the partnership with the City—thus enabling the bidders to propose the model they see as most viable.

For example, a provider might propose to lease all of the City's excess fiber and re-lease it; alternatively, a provider might propose to serve as an independent broker for the City's dark fiber on a commission basis; as another alternative, a new competitor might propose to lease the City's dark fiber to enable it to enter the Lawrence market, or an existing provider might want access to the fiber to supplement and provide redundancy for its existing network and services.

## 8. POTENTIAL STRATEGY 4: OPEN THE LAWRENCE MARKET TO NEW COMPETITION AND COLLABORATION BY BUILDING AN INTERNET POINT-OF-PRESENCE

The purpose of an Internet point-of-presence (POP) is to facilitate interconnection, competition, and peering among entities. A POP is a connection between local and long-distance fiber networks, as well as a meeting or “peering” point between networks. Development of a Lawrence POP would create a junction between the City’s middle- and last-mile fiber and the long-haul fiber that connects Topeka and Kansas City (Figure 19 and Figure 20). It would aggregate the City’s connectivity needs, and, if connected to the backbone link to Kansas City, could be a means to enable the City to connect fiber to the entities located at 1102Grand.com in Kansas City, the “carrier hotel” for Kansas City, which would enable the City to procure services cost effectively from such 1102Grand tenants as Internet bandwidth wholesalers, application providers, and disaster recovery companies.

**Figure 19: Internet Point-of-Presence Would Create Valuable Connection for Lawrence**

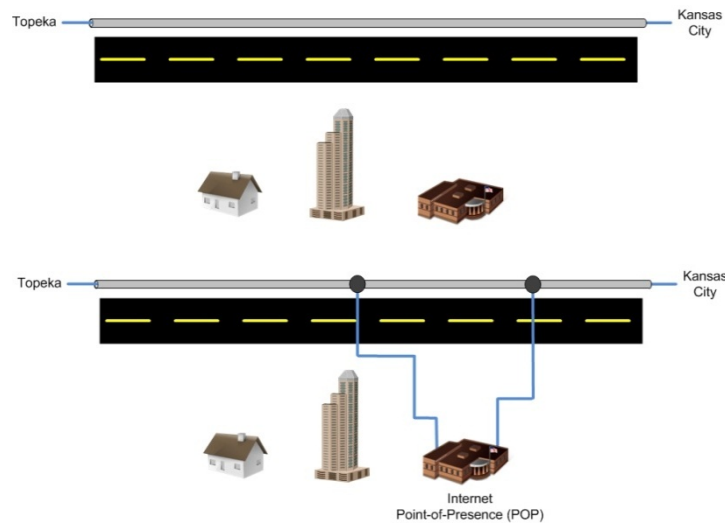

In addition to being an on-ramp to 1102Grand.com, a Lawrence POP would also create access for Level 3 and other long-haul providers, which means lower cost and more connectivity options for the City and its residents. Level 3, in particular, has a very flexible attitude about leasing dark fiber and selling services to meet customers’ needs—which potentially means that Lawrence would have not only a cost-effective way to connect to the POP in Kansas City, but would also enable cost-effective Internet access on a dollar-per-megabit basis. At the same time, such a POP would also potentially be of use to



companies such as CenturyLink who plan to enter the Lawrence market to compete for institutional and business customers.<sup>207</sup>

A Lawrence POP would also create the opportunity for non-transit peering between entities connected there, potentially including local commercial service providers, the City, Lawrence Public Schools, KU, and long-haul providers.<sup>208</sup> Local peering would make it possible to reduce the commodity Internet costs of all connected parties as well as the costs of commercial service providers, because they would not need to pay backbone Internet access fees for a substantial percentage of their Internet use. Internet traffic from students, telecommuters, and individuals seeking access to government resources would not need to travel out of Lawrence to another city and come back again. Under a peering scenario, network performance is also likely to improve.

---

<sup>207</sup> According to CenturyLink's regional business sales manager, the company has started new marketing in Lawrence in just the past few weeks, seeking to leverage the infrastructure it purchased from Qwest. Interview with Bonnie Snyder and colleagues, April 10, 2013.

<sup>208</sup> In King County, Washington and the City of Seattle, Comcast peers with University of Washington and the city and county governments at a public peering point, reducing backbone Internet costs and improving performance for students, telecommuters, residents, and businesses.

Figure 20: Configuration of Lawrence POP Facility

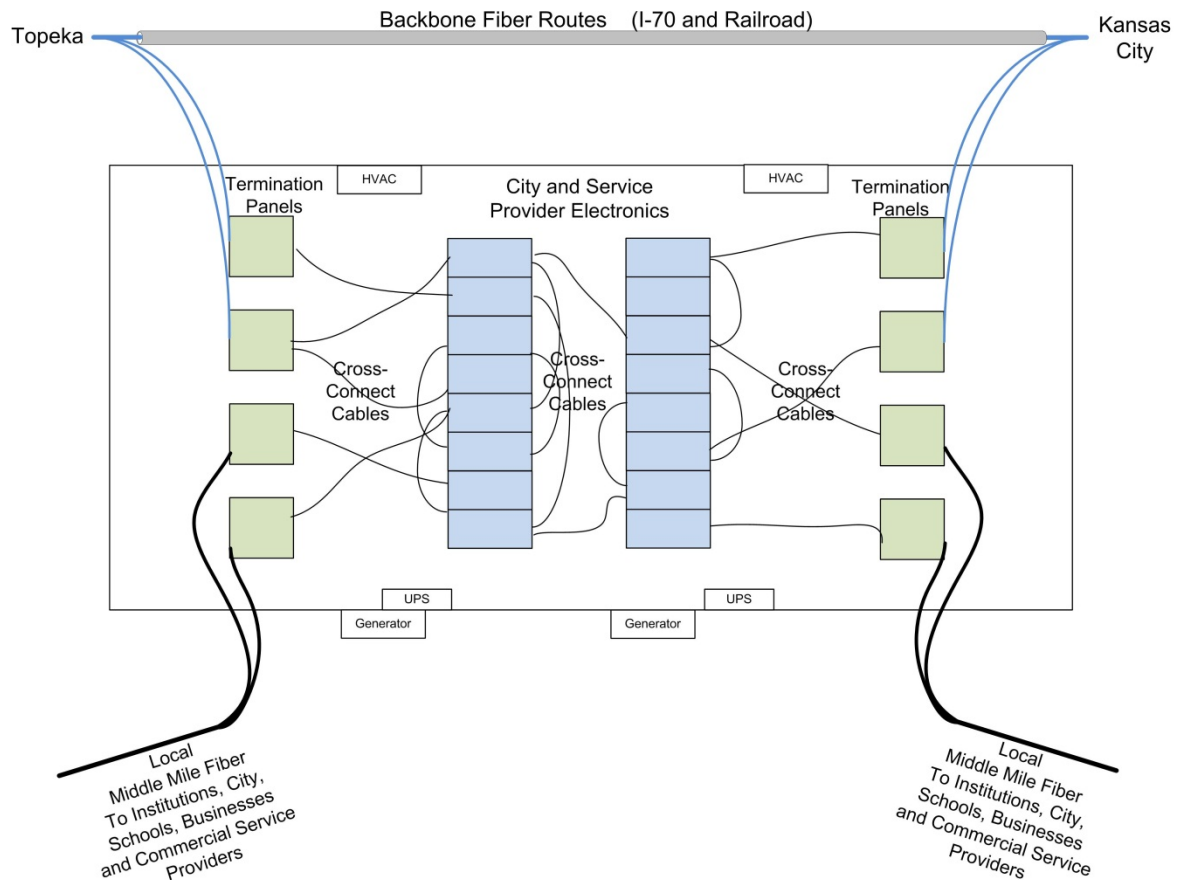

The City's IT Department has already done initial analysis of this opportunity, with some thoughts toward developing a multi-vendor demarcation.<sup>209</sup> The department seeks to build a secure, robust POP on the City's eastern edge as part of the major Farmland development project.

We strongly recommend this project—either at the Farmland site, or at another site that offers enough space, security, and power; has access to the City's existing infrastructure; and can be connected to the major long-distance rights-of-way that run through Lawrence (the railroad and I-70).

Over time, this POP could lead to more competition and lower prices for Internet service in Lawrence.

<sup>209</sup> Wisdom, p. 32.

## 9. POTENTIAL STRATEGY 5: MAKE AVAILABLE TO LOCAL BUSINESSES INFORMATION ABOUT COMPETITIVE SERVICE OPTIONS

Based on our interviews with a wide range of Lawrence businesses, many private sector providers have not effectively marketed their service offerings in Lawrence and, as a result, many Lawrence businesses seem unaware that they have broadband options other than AT&T and Knology. This lack of knowledge presents an opportunity for the City and Chamber of Commerce—which can together educate the local business community about the potential to buy competitive services from companies such as Wicked Broadband, CenturyLink, and Level 3.

A number of the businesses we interviewed expressed significant frustration with existing competitive options and a clear interest in significantly more bandwidth. Technology businesses in particular told us that they will imminently need to double or quadruple their Internet bandwidth and do not have the competitive pricing options in Lawrence that they would have in Chicago or Kansas City. A number of larger businesses noted that they sometimes have to shift work to their locations outside Lawrence because they're Internet connection can't support the functionality necessary. Some also expressed some frustration with customer service from the incumbent phone and cable companies and noted that customer service has deteriorated since the cable network was transferred to an out-of-town owner.

The importance of enabling new fiber to Lawrence businesses is demonstrated by Figure 2, below, which illustrates the comparative upload (sending data up, to the Internet) and download (pulling data down, from the Internet) speeds of various technologies. Note that the faster speeds all require fiber optics and cannot be enabled over legacy copper technologies that are the usual last-mile medium of the phone and cable companies.

Figure 21: Comparative Speeds of Various Technologies

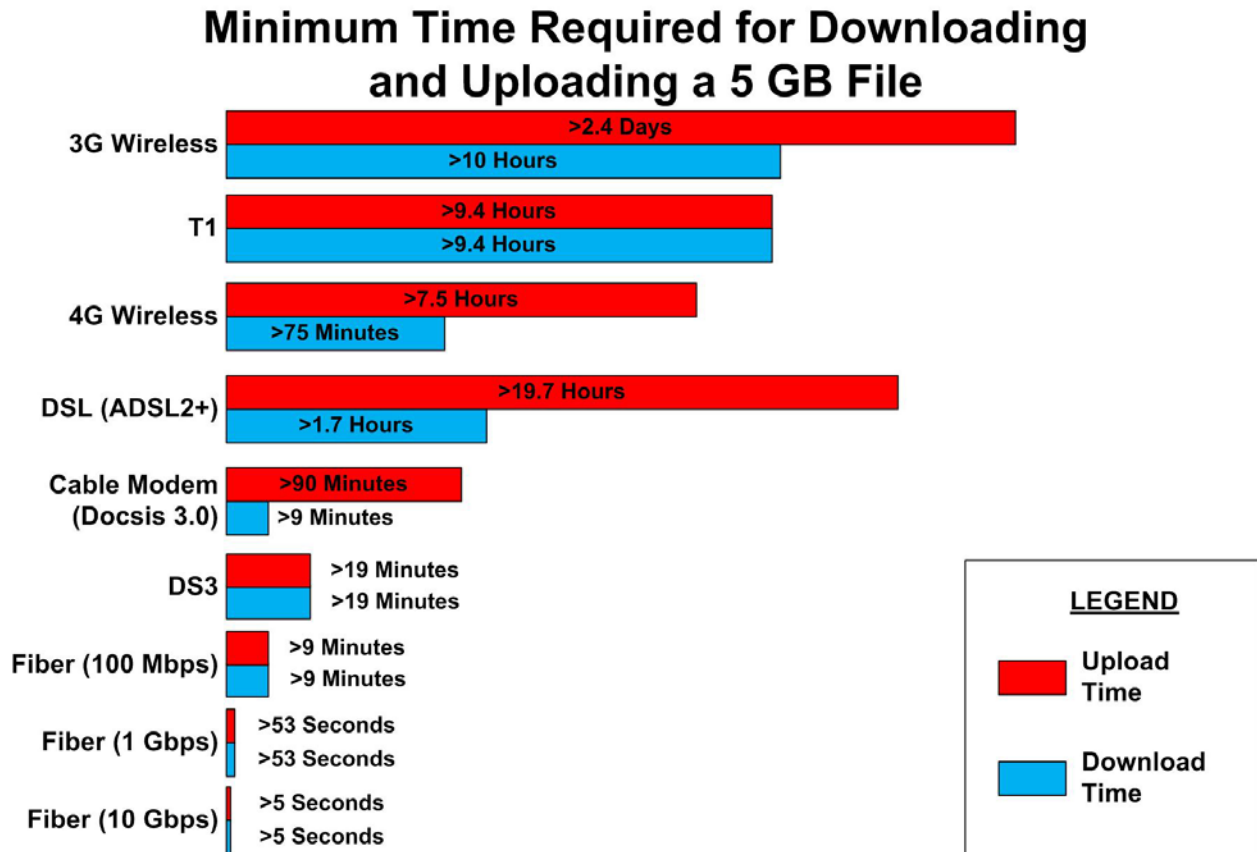

## 10. POTENTIAL STRATEGY 6: BEWARE OF CLAIMS THAT EXPEDITING LOCAL PROCESSES AND REDUCING FEES WILL SOLVE BROADBAND NEEDS

To support models under which the City would facilitate the expansion of private sector broadband infrastructure, we briefly explored options for the City to offer access to real estate and other city property, reduce fees, tweak regulations related to permitting and rights-of-way, and other operational changes—changes that many private sector carriers claim would incentivize private sector investment in broadband expansion.

We conclude that the City is already a very business-friendly environment for private sector providers and, through a range of fiber and conduit projects, has demonstrated its willingness to work with the private sector to enable broadband deployment. We also note that, despite industry claims, changing City practices and regulations is unlikely to serve as a silver bullet to enhance private investment; we believe these claims are dramatically oversold and that there is little empirical data to demonstrate that these strategies alone will lead to increased private sector broadband investment. Rather, the ability to adjust fees and processes is among the tools in a local government's toolkit when the jurisdiction is negotiating with a provider. Lowering fees and the like do not, in and of themselves, comprehensively change the broadband landscape.

While incumbent cable and phone companies nationwide have long claimed that the primary barrier to more broadband investment is local processes and fees related to public rights of way and other public property, in our experience, this impact is marginal at best. Based on CTC's experience observing broadband communications build-out patterns since the advent of the broadband cable platform in the 1970s, changes to such fees and processes as those for permitting or rights-of-way access are unlikely to change the economics of broadband deployment sufficiently to encourage investment where it is otherwise unfavorable.<sup>210</sup>

Frankly, in our experience, there is little that any local government can do to encourage carrier build-out of advanced networks *where the carrier does not already have a compelling business interest and business plan to achieve the same goal*. In that event, however, City efforts to facilitate and streamline processes—and potentially to make assets

---

<sup>210</sup> See CTC, "An Engineering Analysis of Public Rights of Way Processes in the Context of Wireline Network Design and Construction," July 13, 2011.  
[http://ctcnet.us/2011%20CTC\\_Study%20NationalLeagueCities%2011-59.pdf](http://ctcnet.us/2011%20CTC_Study%20NationalLeagueCities%2011-59.pdf)

available to providers—can help that provider to successfully enter the local market, to the benefit of both the provider and local consumers.

Google’s Kansas City investments illustrate this point. Google publicly noted its intent to enter local broadband markets and openly sought (and then privately negotiated) local public partners who would enhance the attractiveness of the investment opportunity by helping to reduce costs. Given this specific and concrete opportunity, both Kansas City, Missouri and Kansas City, Kansas made very rational choices to offer cost-saving benefits to Google so as to attract this unprecedented investment in the local economy.<sup>211</sup>

The Google–Kansas City arrangements have received praise in some quarters as a model for how cities can attract FTTP providers—but we note that there are many more cities seeking broadband investment than there are investment funds seeking projects. Absent Google’s or another well-financed company’s stated intent to invest in FTTP, City efforts to duplicate the Kansas City model is speculative at best. (It has also been noted that the benefits to Google come at considerable public expense and that Google’s project should be recognized as requiring significant local subsidy.)<sup>212</sup>

---

<sup>211</sup> Under the agreement between Google and Kansas City, Missouri, the city provides—at no charge—Central Office and other network facility space, power, office space, rights of way, and dedicated city staff for inspection and other processes.

<http://www.netcompetition.org/wp-content/uploads/Google-Kansas-Agreement1.pdf>

<sup>212</sup> See: <http://arstechnica.com/tech-policy/2012/09/how-kansas-city-taxpayers-support-google-fiber/>

## 11. POTENTIAL STRATEGY 7: PROCEED WITH CAUTION IN CONSIDERING MUNICIPAL FIBER-TO-THE-PREMISES

Beyond the incremental fiber construction that we have recommended above, the City could take a long-term approach to expanding its fiber network and construct a fiber-to-the-premises (FTTP) infrastructure that reaches all residences and businesses in the City. This approach would, potentially, deliver the greatest benefits to the City's residents and businesses by providing ubiquitous access to connectivity at the highest technically available speeds. But constructing an FTTP infrastructure would involve the greatest risks for the City, too: It would require the most construction; would entail the largest municipal investment, in terms of financial and human resources; and would require a long-term commitment to sustaining a substantially expanded operation.

In this section, we present a very high-level model of a potential FTTP initiative, designed to give a snapshot of the order of magnitude of the public funding commitment necessary over time.<sup>213</sup> At a system level, and based on a range of generally applicable assumptions, our engineers estimate that an FTTP network in Lawrence will cost about \$40 million to \$66 million. This cost estimate was based on the City's geography, prevailing utility construction, and typical construction costs. (If the City would like to pursue this option, we recommend more detailed on-site surveys.)

Even in an environment of very lean capital and operating costs, FTTP is challenging to make work from a financial standpoint. Unless the network operator is the incumbent and faces little or no competition, it is a significant challenge for these networks to pay for themselves. Accordingly, CTC advocates for FTTP builds only where the community understands that an ongoing subsidy is possible.

In the event that City Commission is interested in further understanding this model and its sensitivities—its risks and its benefits—we recommend a more comprehensive study that includes statistically valid market research, more detailed engineering and cost estimation, and further data collection to enable the best possible estimation of potential revenues.

---

<sup>213</sup> In addition to the financial risk that the City would face, an FTTP initiative would also entail political and legal risk (of which we know the City is well aware), as well as the risk of predatory pricing and other kinds of practices by incumbent providers—which might increase the financial risk as well.

## 11.1 INCUMBENT FTTP BACKGROUND

Verizon, of all the incumbent cable and phone companies, is the only one to have made a significant investment in FTTP. To our knowledge, the new owner of the cable system in Lawrence, Wide Open West, has not demonstrated any intention of migrating to this technology.

Verizon's FTTP investment began in the early 2000s, and the company sought out cable franchises and then built FTTP quite aggressively in select suburban and urban areas within its existing footprint, primarily on the east coast, but with some investment in the Pacific northwest and other regions.

Of the other incumbent phone companies there has been almost no FTTP investment other than in occasional greenfield developments. With respect to existing homes and businesses, however, AT&T, Qwest, and CenturyLink have taken the approach of modest upgrades to enable DSL service, rather than a wholesale rebuilding effort.

While the cable companies, including Knology, have upgraded their networks to support higher bandwidth services, those upgrades have been accomplished by changes in electronics, not construction of fiber all the way to the premises.<sup>214</sup>

A small number of local and regional entrepreneurs around the country have built FTTP, but these represent a modest footprint and, for the most part, have not demonstrated a new or transformative business model that would make FTTP more viable as a private investment. In addition, rural incumbent local exchange carriers and coops have taken advantage of Universal Service Fund subsidies to support in some cases both the capital and operating costs of FTTP networks. But this, too, is a relatively small footprint relative to rural areas that do not have this kind of infrastructure, and is limited to very rural areas only, and is not a replicable model given the fact that it requires federal subsidy from the Universal Service Fund.

---

<sup>214</sup> The cable migration to higher broadband speeds has been accomplished through migration from DOCSIS 2.0 to DOCSIS 3.0 (and is likely to continue with future, projected DOCSIS 3.1) standards, which increase the speed possible over existing hybrid fiber coaxial plant. As currently postulated, DOCSIS 3.1 will, when it is deployed in coming years, facilitate the migration from a primarily TV channel oriented network to an IP-based multimedia platform, albeit a less scalable one than FTTP. Knology has upgraded to DOCSIS 3.0 in some areas of Lawrence, primarily where it is adding new customers, but some legacy DOCSIS 2.0 operations exist, according to system manager Debbie Schmidt.



## 11.2 MUNICIPAL FTTP BACKGROUND

There is an impressive municipal tradition of local government fiber networks that serve the public rather than only public institutions. More than 100 local communities have built hybrid fiber-coaxial (HFC) networks (the architecture used by the cable companies) or fiber to the premises (FTTP) networks to comprehensively serve the residential and business markets.<sup>215</sup>

Some of these networks date back almost two decades; the great majority were deployed in the first decade of the 21<sup>st</sup> century. In almost every case, these networks have been deployed in towns and largely rural areas, in some of the most conservative parts of the United States. Some, but not all, of these towns already had cable modem service, but many of them were unserved or close to unserved by broadband service at all. The majority of these municipal public-facing networks were deployed by municipal electric utilities.

This correlation is not surprising for a number of reasons. First, it is in communities where the private sector did not have a business case for electrification, where local governments chose to build public power. Not surprisingly, those same communities did not see significant private sector investment in broadband, much as a century earlier they did not see private investment in power—and thus chose, in both cases, to make that investment themselves for the benefit of the broader community.

Secondly, the challenge of undertaking a public-facing communications project is reduced for a municipal electric utility relative to a local government that is not already a power provider. A range of elements of a communications network overlap those of a power network, including the poles on which the infrastructure is built, the facilities in which hubs are located, the skills and equipment of field staff, and even in some cases the billing, operating, and customer service systems that support the service offerings.

A minority of the municipal public-facing networks were built by localities that were not power utilities. It is important to note, however, that even for a municipal electric utility it is challenging to build a self-sustaining FTTP network that generates enough revenue to cover all of its operating expense, including principal and interest payment.

Unlike with other public utilities such as water and sewer, city communications networks do not operate in a monopoly environment, and a number of competitors, however inferior, do exist. These include far lower bandwidth options such as DSL, cable modem service, and

---

<sup>215</sup> Broadband Communities magazine, online database,  
<http://www.bbbmag.com/search.php?s0=1&cols=-co-st-an-se-ty-mu-su-pa&st=&ve=&gr=&te=&se=&ty=-mu-n-ppr&qco=&qme=&qan=&qus=0&qmu=&qsu=&qpa=>

mobile wireless service. (In contrast, some of the municipal FTTP networks were built a decade or more ago at a time when there may not have been much or any competition in those rural towns).

Public power utilities are frequently better positioned to build and operate self-sustaining FTTP networks than are cities without public power because of all the overlaps and efficiencies in both infrastructure and operations—shared use and benefits mean that some network costs can be shared between the power and communications enterprises to the extent approved by the relevant regulatory authority.

Tremendous successes have been achieved by such public FTTP networks as those in Lafayette, Louisiana; Chattanooga, Tennessee; and Bristol, Virginia—all of which are municipal electric utilities that achieved substantial efficiencies.<sup>216</sup>

In some cases, in addition, federal funding such as Recovery Act funding for Smart Grid has been awarded to the electric utility and has enabled additional construction of fiber optics for energy use that also support the communications utility.

The most dramatic successes of these networks are in the benefits that do not show up on the financial statements—the enhanced productivity, education, health care, company recruitment, and related benefits that are the reason for the communications investment in the first place. Thus, even though those public entities that have found that making FTTP networks self-sustaining challenging, can claim significant success based on these other benefits—which some call positive externalities or ancillary benefits, but that are in our opinion more central to the purpose of the network than any other factor.

### 11.3 LAWRENCE FTTP NETWORK MODEL

At a high level, we estimate approximately 60 percent aerial construction (i.e., on utility poles) and 40 percent of the infrastructure buried underground, based in information provided by Westar.

Figure 22 illustrates the backbone fiber routing and potential FTTP routing; Figure 23 illustrates a sample fiber design from a hub to customer premises.

---

<sup>216</sup> Kendrick, Julie, “The Broadband Challenge,” *The Line*, July 18, 2012. <http://www.thelinemedia.com/features/broadband071812.aspx>. See also: Mitchell, Christopher, “Broadband At the Speed of Light: How Three Communities Built Next-Generation Networks,” Institute for Local Self-Reliance, April 2012. <http://www.ilsr.org/wp-content/uploads/2012/04/muni-bb-speed-light.pdf>

Figure 22: FTTP Hub Design

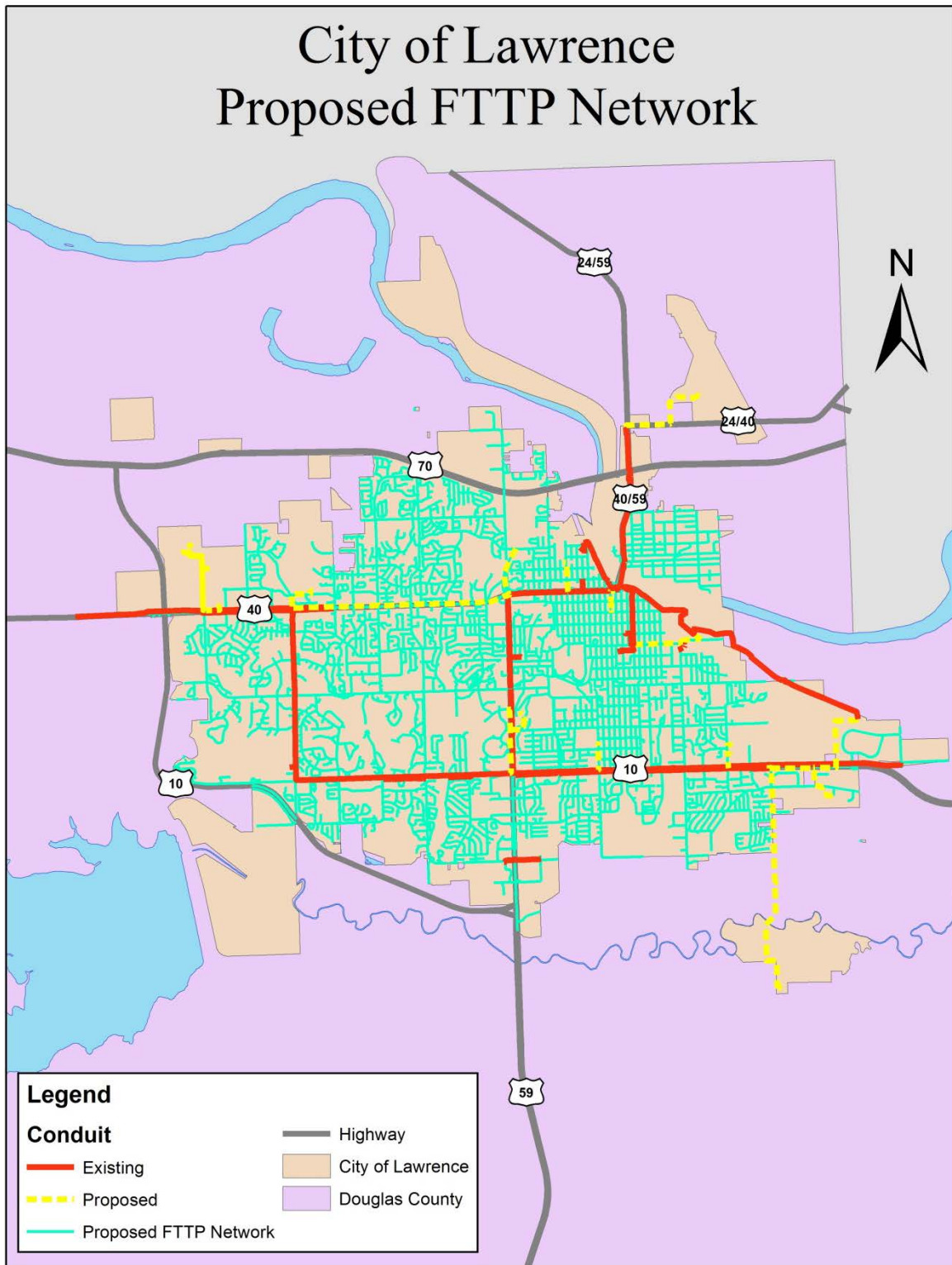

Figure 23: FTTP Distribution Design



With our estimated aerial/underground portions as a guide, and assuming that 40 percent of Lawrence’s residents and businesses<sup>217</sup> subscribe to these services, we estimate that an FTTP deployment would cost up to about \$70 million. Using the City’s existing conduit and fiber backbone reduces the cost of the FTTP project by about \$2 million, representing a savings but not enough to substantially improve the cash flow picture.

Because the costs of electronics and drops (connections from the network to the home) are a per-customer expense, the cost of the network increases as the number of subscribers increases. The cost breakdown is shown in Table 11 below.

**Table 11: High-Level FTTP Cost Estimate**

Item	Units	Unit Cost (low)	Unit Cost (high)	Total Cost (low)	Total Cost (high)
Aerial Construction (Feet)	1200000	\$8	\$12	\$9,600,000	\$14,400,000
Underground Construction	700000	\$16	\$24	\$11,200,000	\$16,800,000
Central Hub Preparation and Electronics *	1	\$1,000,000	\$2,500,000	\$500,000	\$2,500,000
Single Family Service Drops*	28000	\$400	\$600	\$ 4,500,000	\$6,750,000
Multi Dwelling Service Drops*	9500	\$250	\$600	\$1,000,000	\$2,250,000
Outdoor Cabinets*	80	\$25,000	\$70,000	\$2,000,000	\$5,600,000
Electronic Equipment (Household)*	37,500	\$500	\$800	\$7,500,000	\$12,000,000
Engineering	1900000	\$2	\$3	\$3,800,000	\$5,700,000
<i>Total</i>				\$40,100,000	\$66,000,000

\* Depends on subscriber penetration—assumes 40% of serviceable passings subscribe

#### 11.4 FTTP FINANCIAL MODEL

Utilizing the general cost estimate described above, CTC conducted a basic financial analysis of the viability of a potential FTTP network. Like the design and cost, this analysis is very preliminary and would require extensive additional research and refinement in the event that the City wishes to conduct detailed feasibility analysis of this strategy.

<sup>217</sup> We base our estimates on the number of households, multi-dwelling units, and businesses identified in the U.S. Census Bureau’s most current QuickFacts overview for Lawrence. See <http://quickfacts.census.gov/qfd/states/20/2038900.html>.

Our preliminary analysis assumes that the project will require ongoing staffing by 35 full-time employees, including customer service representatives and service technicians. The model also assumes that the City will not deliver content itself, but will contract with wholesale providers to deliver video, data, and voice content. Under this model, the City will provide retail (sales, marketing, support) and transport services.

Based on these preliminary cost assumptions, a market share in excess of 50 percent would be required to reach a cash-neutral operation. We caution that this represents an extremely challenging goal: In many FTTP overbuilds, including both public and private initiatives, we see a market share slow-down at around 30 percent penetration and an effective ceiling on sales at around 40 percent.

We conclude, based on this very basic and preliminary analysis, that City FTTP would be challenging to sustain as a standalone enterprise. Unless statistically-valid market research demonstrates that a City-owned network could attract significantly more than half the residential and business market, the initiative would require long-term financial support.

Significantly, this analysis addresses only the quantifiable financial factors that are relevant to the business case for the network. Many of the additional benefits of the network are such key items as economic development, small business empowerment, job creation, livability, education, increased property values, and other factors that measure the overall benefit of a next-generation communications infrastructure such as FTTP. As a result, many communities define their success metrics more broadly and consider the “beyond the balance sheet” benefits that such a network would deliver. These benefits have nothing to do with traditional financial measures. Rather, they represent the “return” to the community in terms of such largely intangible societal benefits as enhancing health care quality, narrowing the digital divide, providing enhanced educational opportunities to schoolchildren, delivering job search and placement opportunities at public computer centers, and helping isolated senior citizens make virtual social and health connections.

Why is this approach a justifiable and appropriate way to define the success of a network? Because these benefits are the true reasons that governments build broadband infrastructure in the first place. Local governments are in the business of providing education for their young people, job training for their unemployed, and so on; broadband is just the latest, and newly essential, tool to enable those public goals.

## 11.5 NEXT STEPS FOR FTTP

In the event that the City chooses to further evaluate FTTP, particularly the emerging new models such as Google's "fiberhood" neighborhood self-nomination process, we recommend the following activities be undertaken:

1. Extensive, scientific surveys of the residential and small business markets to determine citizens' satisfaction with current services and pricing; the needs they are likely to have for communications services in the coming decade, and their willingness to participate financially in the emergence of a next-generation communications infrastructure. An additional benefit of such survey efforts would be to provide the data inputs for a more sophisticated business model, enabling more reliable revenue projections—either for the city's own initiative, or to attract a private partner—by quantifying the potential market.
2. Preparation of a system-level design for ubiquitous fiber to the premises in Lawrence. Order-of-magnitude engineering was performed for this project, but should the City decide to move to the next phase of planning, those costs should be refined based on the potential business model, and a more detailed operations model should be developed.
3. Preparation of a fiber-to-the-premises business plan. Ideally, a number of variations—ranging from full municipal ownership and operations to a range of public-private partnership models in which the city shares some of the risk of the initiative—should be examined for their feasibility. Both the benefits and risks of these models should be quantified, to enable the City Commission and the public to fully understand the range of options.

## 12. STRATEGY 8: WORK WITH KU TO JOIN GIG.U TO POTENTIALLY ATTRACT FTTP INVESTMENT

We recommend that the City work with the University of Kansas to explore joining the Gig.U consortium and potentially seeking a private partner for more extensive fiber deployment in Lawrence. KU is a logical Gig.U member—an elite research university with a sophisticated technology operation and extensive fiber optics of its own. And KU is located in an underserved but attractive city market and has a strong, engaged partner in the form of the City of Lawrence. The Gig.U process of internal planning and working to seek extensive private investment could be an important strategy for Lawrence.

### 12.1 BACKGROUND REGARDING GIG.U

Recent months have suggested new strategies for localities to explore if they seek private investment to build extensive fiber to homes and businesses. The new opportunities seem to have arisen from the new excitement around fiber after Google's Kansas City announcement. As the Google project emerged, policymakers and entrepreneurs noted the extent of the interest of potential Google communities, and the fact that many were offering to do everything they could to attract the company's investment, from providing infrastructure to aggregating buying power to exercising any other potential leverage they might have. In part based on that remarkable outpouring of interest, a number of initiatives emerged.

The most significant of these initiatives is Gig.U (“the University Community Next Generation Innovation Project”),<sup>218</sup> which is the creation of Blair Levin, a Washington-based communications policymaker. Levin was the architect of the Federal Communications Commission's (FCC) 2010 National Broadband Plan and previously served as FCC chief of staff during the first part of the Clinton administration. After he left the FCC in 2010, Levin founded Gig.U and developed a membership of 37 universities that demonstrated an interest in trying to help catalyze the development of fiber-to-the-premises (FTTP) in their communities. Then he solicited interest and ideas from private and public entities through a request for information (RFI) process to try to understand what might attract private providers to invest in local FTTP in and around university communities.

---

<sup>218</sup> Gig.U website, <http://www.gig-u.org/>.



Levin believes that localities can potentially “change the math” and enhance the attractiveness of private investment, by lowering costs and by increasing potential revenues in a local community. Through guaranteed government and institutional revenues, changes to codes and fees, and access to public infrastructure, localities may be able to attract providers that are willing to make investments.

## 12.2 NEW PRIVATE INVESTMENT IN ROBUST FIBER NETWORKS HAS EMERGED IN RESPONSE TO GOOGLE AND THE GIG.U EFFORT

At least one provider that appears interested in such a model responded to this RFI and then partnered with Gig.U. Gigabit Squared, a start-up fiber development firm, released a request for proposals (RFP) to the Gig.U universities, soliciting bids from the universities (in partnership with their surrounding communities) to attract the \$200 million in start-up funding Gigabit Squared reportedly has raised.

Other companies appear also to be entering the market. For example, the project known as North Carolina Next Generation Network (NC NGN) announced this month that it received eight competitive responses to its RFP, which was issued by four Gig.U universities and six surrounding communities in the Raleigh-Durham area. While the identities of the eight respondents were not revealed, Time Warner announced that it is among the respondents. We are presuming that Gigabit Squared and other small, entrepreneurial companies are also respondents to NC NGN.

Gigabit Squared plans to invest in a number of U.S. communities, perhaps as many as six, over the next few years.<sup>219</sup> Gigabit Squared’s business model will depend on the development of local applications, extensive local engagement, and growing beyond the standard triple-play of voice, video, and data service to include enhanced services that would presumably increase Gigabit Squared’s revenues. As of this writing, Gigabit Squared has announced partnerships with consortia representing neighborhoods in Chicago and Seattle.

From our standpoint, the most significant factor that differentiates Google, Gigabit Squared, and possibly the NC NGN bidders from other FTTP initiatives that we have seen arise over the past decade is that they do not appear to be asking for municipal funding or municipal guarantee of the private investment. While presumably these companies (like Google in Kansas City) are looking for municipal assistance in reducing costs—through such benefits as dedicated inspectors, waived rights-of-way fees, and so on—it does not appear that they

---

<sup>219</sup> <http://gigabitsquared.com/>. See also: “Gigabit Neighborhood Gateway Program,” Gigabit Squared website, May 23, 2012. <http://gigabitsquared.com/new-website-launch/>

expect the localities to fund, finance, or guarantee its investment (at least as of now). In our experience, this is a new dynamic in the FTTP market.

### 12.3 NEW CITY INITIATIVES ARE EMERGING TO SEEK PARTNERSHIPS WITH NEW INVESTORS

If companies like Gigabit Squared are successful in building sustainable, profitable FTTP networks, the outcome of the new round of projects will be to demonstrate a new business model for competitive builds of FTTP—a dramatic shift in the status quo and an important matter to watch—and potentially for the City to engage.

Other communities seem to have identified that such opportunities exist. The NC NGN project mentioned above is one high-profile effort to attract new, entrepreneurial private investment. Another initiative is underway in Urbana and Champaign, Illinois, where the cities, in partnership with the University of Illinois (a Gig.U member), have built extensive fiber rings and some fiber to low-income homes and are now seeking a private partner to invest in building to the rest of the communities and operating the network. While the status of their efforts is not public, the cities have announced that they are in the process of interviewing and vetting potential partners.

### 13. STRATEGY 9: LEVERAGE THE CITY'S PROXIMITY TO KANSAS CITY AND COMMUNICATE WITH GOOGLE

Three years ago, Google attempted to disrupt and shake up the rather static picture around broadband in the United States. This project attracted enormous attention when it was announced—and received more than 1,100 applications from American cities and counties seeking Google's FTTP investment, including Lawrence. Ultimately, in 2011 Google selected Kansas City, Kansas and Kansas City, Missouri as the sites for its new network. In recent weeks, it has also announced extension of that network to Olathe, Kansas and a new fiber project in Austin, Texas. We anticipate additional future announcements from Google, perhaps in as many as eight to 10 metropolitan areas.

As Google activates its networks, attention will shift to what the network can do, and what it portends for the competitive landscape.<sup>220</sup>

In the time since Google first announced its fiber plans, there has been a significant impact on the broader environment. The astonishing response to Google's announcements, in the form of the 1,100 applications by would-be Google communities, was noted in Washington by some policy makers—but also outside Washington by entrepreneurs thinking about the fiber market.

A number of initiatives have thus indirectly arisen from Google's announcements and plans. This is not a coincidence; part of what Google was trying to accomplish was to spur the emergence of new models for big fiber construction. More bandwidth means more Internet use, and Google's business model is premised on customers being able to use its services. Like many of us, Google was very concerned that there was no plan or path forward for construction of wireline communication networks in the United States. At the time of its initial announcement, Google's aim appeared to be that it would demonstrate scalable new business models.

Google's efforts appear not only to have increased investor interest in the FTTP market but also to force incumbent phone and cable operators to consider how to respond to the newly competitive environment, even though that competition extends only to three cities thus far. In Austin, AT&T has announced plans to build comparable fiber infrastructure, though it has also declined to specify a timeframe. And as noted above, Time Warner has

---

<sup>220</sup> See, for example: Reardon, Marguerite, "Google shows ISPs how to build a superfast network," *CNET*, July 26, 2012.  
[http://news.cnet.com/8301-1023\\_3-57481108-93/google-shows-isps-how-to-build-a-superfast-network/](http://news.cnet.com/8301-1023_3-57481108-93/google-shows-isps-how-to-build-a-superfast-network/)

announced that it is among the respondents to the RFP issued by the NC NGN project in the Raleigh-Durham area.

In Kansas City, we have not noticed extensive new construction by Time Warner in response to Google's efforts, but we have noticed that Time Warner has engaged in aggressive new efforts to sell long-term contracts; reduced pricing across all sectors; greatly improved customer service; and marketed a product for low-income consumers. In short, competition is working to the benefit of Kansas City consumers.

### 13.1 GOOGLE'S BUSINESS MODEL

One important aspect of the Google process is a relatively new business model that Google recently announced—and that, depending on Google's level of success, may demonstrate a new direction for FTTP financing and construction. Specifically, Google has divided Kansas City into regions that it calls "fiberhoods." It is prioritizing the build of FTTP facilities to those fiberhoods that reach critical mass with respect to pre-commitments to purchase service.<sup>221</sup>

With the additional benefit of significant cost-saving measures that the two cities agreed to (including the provision of dedicated inspectors, expedited permitting, waiver of permitting and rights-of-way fees, and free access to real estate, power, and other facilities), Google is now planning to construct its network in the fiberhoods that are most financially viable, as demonstrated by its future customers' advanced indications. Google has also committed to building state-of-the-art facilities to community anchor institutions such as schools and libraries—though it will build to anchor institutions in a particular neighborhood only when it builds to the surrounding fiberhood, again based on residents' pre-commitment levels.

Therein lies the most important shortcoming of this business model from the standpoint of local economic development and local community interest. Google is able to build only where it will have the most customers; only the anchor institutions in those neighborhoods, which will presumably be those that are best able to afford and are most interested in state-of-the-art services, will get their facilities in that timeframe. It is not clear whether Google will ever build to neighborhoods and anchor institutions where there is not substantial consumer interest.<sup>222</sup> This model makes the investment far more

---

<sup>221</sup> "What is a fiberhood" and "How do I get Fiber service for my home?," Google Fiber "Frequently Asked Questions" web page. <https://fiber.google.com/help/>.

<sup>222</sup> "Google Fiber: Will It Bypass Those Who Need It Most?," Schools, Health & Libraries Broadband Coalition website.

<http://www.shlb.org/blog/index.cfm/2012/9/4/Google-Fiber-Good-newsBad-News-for-Community-Anchor>

profitable for Google, but potentially accentuates and underscores the digital divide rather than ameliorating it. And while all Kansas City taxpayers are supporting Google's network (through free access to public property, power, and dedicated staff),<sup>223</sup> only Kansas City taxpayers in certain fiberhoods will have access to Google's services—whether at home, work, or at essential anchor institutions such as libraries.<sup>224</sup>

The shortcomings of the Google model can, however, potentially be addressed through certain mitigation strategies. For example, the Urbana-Champaign Big Broadband (UC2B) network, an intergovernmental initiative in Illinois, has been exploring using this model since long before Google announced its fiberhood plan. However, the cities of Urbana and Champaign started by applying for and receiving federal funding to build FTTP in the poorest parts of its planned network footprint—thus beginning with the least economically viable neighborhoods rather than the most.

The cities of Urbana and Champaign are in the process of negotiating with potential private providers to complete their network, and among their core requirements for that provider are two that are designed to avoid the risks of fiber exclusion: First, they require that the provider build to the entire community, with no redlining for economic or other reasons; and second, that the provider pay a percentage of its revenues into a digital inclusion fund. The digital inclusion fund will pay for community education efforts in low-income and low digital literacy communities, with the goal of enhancing adoption in less commercially viable neighborhoods (and thus improving the business prospects for the private partner in those neighborhoods).

Even should private investment not materialize, however, Urbana and Champaign do tentatively intend to expand the network beyond the federally financed, low-income areas—and to do it on essentially the same model as Google, building first to neighborhoods with substantial pre-commitments that are therefore more financially viable.

This model has been discussed over the years, and has recently been tested by the Utah Telecommunication Open Infrastructure Agency (UTOPIA) network in Brigham City, Utah,<sup>225</sup> but it has never been tested in the United States to the degree that it will be by

---

<sup>223</sup> <http://arstechnica.com/tech-policy/2012/09/how-kansas-city-taxpayers-support-google-fiber/>

<sup>224</sup> See, for example:

<http://www.nytimes.com/2012/09/10/us/in-one-city-signing-up-for-internet-becomes-a-civic-cause.html?r=1&pagewanted=all>; and

<http://www.siliconbeat.com/2012/08/30/will-google-fiber-make-digital-and-racial-divide-in-kansas-city-worse/>

<sup>225</sup> "Brigham City Develops Alternative Method to Finance Publicly Owned FTTH," Community Broadband Networks website, Institute for Local Self Reliance.

Google. How it develops and the data that emerge from the Kansas City, Brigham City, and UC2B experiments will be extremely important to determining potential future FTTP models.

### 13.2 THE CITY SHOULD ESTABLISH CONTACT WITH GOOGLE IN FOLLOW-UP TO CTC'S CONTACTS

As part of our analysis of options for the City to leverage its existing infrastructure, CTC spoke to Rachel Hack, Community Manager for Google Fiber in Kansas City. Recognizing that Google's fiber network will not be limited solely to Kansas City—the company recently announced plans to extend its fiber to the City of Olathe, Kansas, for example<sup>226</sup>—we presented the case for building fiber to Lawrence. Ms. Hack was understandably noncommittal, but she noted that Google is expanding in Johnson County—and she asked that the City send a letter of interest to establish its willingness to enter discussions in the future.

---

<http://www.muninetworks.org/content/brigham-city-develops-alternative-method-finance-publicly-owned-ftth>

<sup>226</sup> Hack, Rachel, "Google Fiber is coming to Olathe, Kansas," Google Fiber blog, March 19, 2013. <http://googlefiberblog.blogspot.com/2013/03/google-fiber-is-coming-to-olathe-kansas.html>